



**Alternative Fuels for Marine
Applications:
Future Marine Fuels Study**

IEA – AMF Annex 41 Report (Final)

May 2013

Fuels, Engines and Emissions Consulting

Danish Technological Institute

With support from:

**Danish Maritime Fund
Danish Energy Agency (EUDP 2011-1)**

**Sponsoring Countries:
Denmark, Finland, Germany**

Acknowledgement

The IEA-AMF Organization is grateful for the support of the following countries and their representatives for providing funding for the research to develop this report. The work has been most interesting and informative.

Denmark - Jesper Schramm, Technical University of Denmark (DTU)

Finland - Nils-Olof Nylund, The Technical Research Centre of Finland (VTT)

Germany ó Birger Kerckow, Fachagentur Nachwachsende Rohstoffe (FNR)

Executive Summary – Annex 41

The marine shipping industry is facing challenges to reduce engine exhaust emissions and greenhouse gases (GHG) in particular carbon dioxide (CO₂) from their ships. International regulatory bodies such as the International Maritime Organization (IMO) and national environmental agencies of many countries have issued rules and regulations that drastically reduce GHG and emissions emanating from marine sources. These new rules are impacting ships that engage in international and coastal shipping trade, the cruise industry, and ship owners and operators. Of particular note are regulations in Emissions Control Areas (ECAs) such as the North American ECA which came into effect in 2012 and the SO_x Emission Control Areas (SECA) which have been in effect in the Baltic Sea and North Sea and English Channel since 2006 and 2007 respectively. Ships operating in the ECAs and SECAs are required to use lower sulfur fuels or add SO_x exhaust scrubbers. It is also expected that future ECAs will be coming into effect in countries that see heavy ship traffic. Short term local (SECA/ECA) NO_x and SO_x reductions are the most pressing issues as a result of these regulations. In the longer term GHG and PM emissions will provide further environmental challenges.

Many ship operators, with current propulsion plants and marine fuels cannot meet these new regulations without installing expensive exhaust aftertreatment equipment or switching to low-sulfur diesel, low sulfur residual or alternative fuels with properties that reduce engine emissions below mandated limits, all of which impact the bottom line profits. The impact of these new national and international regulations on the shipping industries worldwide has brought alternative fuels to the forefront as a means for compliance. The alternative fuels industry has grown dramatically for both liquid and gaseous fuels. Each of these alternative fuels has advantages and disadvantages from a shipping industry standpoint.

This report examines the use of alternative fuels for use by the marine shipping industry to satisfy or partially satisfy the new emission and fuel sulfur limits. It also looks at exhaust after treatment devices that can be used to lower the engine exhaust emissions.

A large part of the marine fuel consumption (approximately 77%) is low quality, low price residual fuel referred to as heavy fuel oil (HFO) which tends to be high in sulfur and is almost entirely consumed by large cargo carrying ships. The average fuel sulfur content of HFO used today for marine diesel engines is 2.7% with a maximum allowable limit of 4.5% which presents challenges as the required fuel sulfur levels in the ECAs and globally is reduced. Almost 90 % of the world's marine fuel is used by cargo ships. This report only deals with fuels suitable for heavy duty diesel engines providing propulsion and auxiliary energy on commercial ships which is the bulk of marine fuel consumption.

Currently the most practical solution is the use of low sulfur fuels when in an ECA and other low sulfur fuel situations. There are liquid biofuels and fossil fuels that are low in

sulfur and can satisfy the fuel sulfur requirements of the ECAs and MARPOL Annex VI. In lieu of using low sulfur liquid fuels the use of scrubbers fitted in the engine exhaust to remove the SO_x is another option

The report looks at a variety of liquid fossil and biofuels. Liquid biofuels that are available for marine use are Biodiesel, (Fatty Acid Methyl Ester (FAME)), Algae Fuels, Methanol, Hydrogenation-Derived Renewable Diesel (HDRD) which is also known as second generation biodiesel, and pyrolysis oil. The advantages and disadvantages of these fuels for marine use are discussed.

The aftertreatment approach for meeting the NO_x and SO_x limits is to install emission compliant engines or Selective Catalytic Reduction (SCR) equipment for NO_x reduction and exhaust aftertreatment devices known as scrubbers for SO_x reduction. When looking at these technologies the cost tradeoff for their installation, operation, and maintenance versus the cost of the alternative fuel must be considered. The report discusses the economics and breakeven point for using scrubbers versus conventional fossil fuels based on operations within an ECA.

Gaseous fuels are another option but require a different type of fuel handling system, fuel tanks and gas burning engines that are not currently in use on most ships. The gaseous fuels that are available for marine use are Natural Gas and Propane (LPG). These fuels not only are very low in sulfur content they combust such that NO_x, PM, and CO₂ are also reduced. Natural gas can be carried as a compressed fuel called Compressed Natural Gas (CNG) or in a liquid state called Liquefied Natural Gas (LNG).

Currently the price of natural gas is very attractive and as such is a good candidate for a ships fuel. There are a number of ships that have been built to use natural gas as fuel mostly in the coastwise trade or on fixed routes such as ferries.

At present vessels using natural gas as a fuel are in the small to medium size range with larger ships being built or converted for operation on LNG fuel. The only large ships currently using LNG as a fuel on international voyages are LNG cargo carriers.

For LNG to become an attractive fuel for the majority of ships a global network of LNG bunkering terminals must be established or LNG fueled ships will be limited to coastal trades where there is an LNG bunkering network. The situation is sometimes described as a "chicken and egg" dilemma. Until the bunkering infrastructure is in place the ship owners may not commit to natural gas fueled ships and visa-versa. Currently LNG bunkering is more expensive and complicated than compared to fossil fuel bunkering and is only available in limited places. The port of Stockholm, Sweden has established an LNG bunkering port with dockside fueling and a special purpose ship for ship-to-ship LNG fueling.

As the shipping industry considers alternatives to HFO, part of the market will shift towards Marine Gas Oil (MGO), part towards LNG or other alternative fuels. Marine vessels equipped with scrubbers will retain the advantage of using lower priced HFO.

Shipping that takes place outside ECA areas might choose HFO or LSFO depending on future global regulations. Ships operating partly in ECA areas will probably choose MGO as a compliance fuel. Heavy shipping within ECA areas however might be incentive enough for a complete shift to LNG.

Compliance with the new emission requirements will raise operating costs for ship owners and operators in terms of new construction ships that will have more complicated fuel systems, and perhaps after treatment devices and more expensive low sulfur fuels when in the ECAs and other low sulfur compliance ports and coastal waters. Existing ships which do not have dual tanks may have to be retrofitted with dual fossil fuel systems for fuel switching when they enter an ECA.

Contents

1. Introduction	1
2. Background.....	1
3. Current Situation.....	5
3.1 Legislation for Marine SO _x Reduction	5
3.2 Legislation for Marine NO _x Reduction.....	5
3.3 Compliance with Marine SO _x and NO _x Legislation	6
4. Fuel Prices and Availability	8
5. Alternative Marine Fuel Incentives	12
6. Alternative Marine Fuels and Engines.....	13
6.1 Liquid or Crude Based Fossil Fuels (IFO,LSFO,MGO and MSAR2 Bunker Oil).....	14
6.2 Liquid Biofuels (Fuels from vegetable oils and animal fats, straight, hydrogenated or esterified)	16
6.3 Gaseous Fuels	18
6.4 Exhaust Gas Treatment Systems (EGTSs).....	20
7. Assessing Alternative Fuels for Marine Use	22
7.1 Liquid Fossil Fuels (ULSD, LSRF) Advantages:	23
7.2 Liquid Fossil Fuels (ULSD, LSRF) Drawbacks:.....	24
7.3 Liquid Biofuels Characteristics:.....	25
7.4 Gaseous Fuels (Natural Gas (Compressed (CNG) or Liquefied (LNG)).....	29
7.5 Natural Gas Drawbacks	30
7.6 Future Marine Fuel Use.....	41
8. Vessels Using Alternative Fuels	42
8.1 Vessels Using ULSD and LSRF.....	42
8.2 Vessels Using Natural Gas	42
8.3 Vessels Using Liquid Biofuels.....	48
9. The Way Forward for Future Marine Fuels	49
10. Conclusions	52
11. Recommendations.....	54
References:	55
Appendix A ó Marine After Exhaust Treatment Systems	60

List of Figures

Figure 1. Current and Possible Future ECAs (Ref. 2)	2
Figure 2. North European SECA Effective from August 11th 2007 ó (Ref. 4)	3
Figure 3. Ship Operatorø Challenges	4
Figure 4. IMO Diesel Engine NOx Emission Limits.....	6
Figure 5. Global Marine Fuel Consumption Estimates, IMO 2009 (Ref. 11).....	8
Figure 6. Typical Heavy Marine Fuel Type Distribution	9
Figure 7. Global Marine Fuel Use Estimated from IMO and Singapore Port Bunkering Statistics 2009.	9
Figure 8. The Total World Marine Fleet According to IMO (Ref. 11).	10
Figure 9. World Bunker Fuel Demand (Ref. 10).....	10
Figure 10. Bunkerworld Index Prices of HFSO380 and MDO.....	11
Figure 11. Cost of Lighter Low Sulphur Fuels Compared to High Sulphur Bunker Fuel.....	11
Figure 12. Sulphur Content of Conventional Marine Fuels (Ref. 4)	14
Figure 13. Wärtsilä Direct Injection Dual Fuel Concept for Methanol in Large Four Stroke Engines... 18	
Figure 14. Wärtsilä Port Injection Dual Fuel Concept for Gas Use in Large Four Stroke Engines..... 20	
Figure 15. Cost of Scrubber Systems [Couple Systems, Alfa Laval].....	22
Figure 16. Comparison of 50/50 Blend of Algae and F-76 Petroleum Fuel with Petroleum F-76. 27	
Figure 17. Projected Prices of Marine Fuels (Ref. 43)	29
Figure 18. Weights and Volumes of Marine Fuels	32
Figure 19. LNG Bunkering Ship øSeagasø alongside Viking Grace.....	34
Figure 20. Existing and Planned Production Plants and LNG Terminals in the SECA (Ref. 26)	39
Figure 21. LNG Bunkering Barge	40
Figure 22. øBit Vikingø with LNG Fuel Tanks on the Main Deck	45
Figure 23. LNG tanks on top deck of WSF Issaquah Class ferry	46
Figure 24. Concept Illustration of TOTE Container Ship.....	48
Figure 25. Fuel Selection Process is Responsibility of Charterer	50
Figure 26. Break Even Analysis for Scrubber Installation	51
Figure 27. SCR Solution by MAN (reduces NOx).....	60
Figure 28. Advanced EGR System by MAN	61
Figure 29. Scrubber System by Alfa Laval.....	62
Figure 30. Ficaria Seaways Equipped with Presumably Worldø Largest Retrofit Scrubber in 2009 63	
Figure 31. Closed Loop Scrubber by Wärtsilä	63
Figure 32. Dry Scrubber System by Couple Systems, Germany.....	64

List of Tables

Table 1. MARPOL Annex VI Marine SO _x Emission Reduction Areas with Fuel Sulfur Limits	5
Table 2. MARPOL Annex VI NO _x Emission Limits.....	6
Table 3. Feedstocks and Derived Fuels	13
Table 4. Marine Fuel Prices July 2012 in USD/Metric Ton (MT)	24
Table 5. Costs Associated with Converting Marine Vessels to LNG Operation	31
Table 6. Fuel Usage and Storage Volumes for Three Types of Vessels.....	31
Table 7. 2020 Marine Fuel Mix (Mton/year)	41
Table 8. Current Order Book for New LNG Fueled Vessels (2012-2015).....	44
Table 9. Summary of Evaluation of Propellant Systems	53

1. Introduction

Recent fuel sulfur and emission limits imposed on the shipping industry are causing the industry to look at alternative fuels as a way of complying with the new limits. This study focuses on the details of these new emission requirements, their implementation time frame, the types of alternative fuels available for complying with these requirements, the costs of compliance depending on the pathway taken, and alternative methods such as exhaust gas scrubbers for lowering the exhaust emissions.

The report discusses in detail the advantages and disadvantages of liquid fossil and gaseous fuels, and biofuels that are available for marine use and can help ship owners and operators comply with the fuel sulfur and exhaust emission limits.

Also discussed are marine vessels currently using alternative fuels and vessels being converted to use or being built with alternative fuel power propulsion plants.

Lastly this reports looks at the future of alternative marine fuels with conclusions.

2. Background

The world's total liquid fuel supply is currently at approximately 4,000 Megatons per year. Marine liquid fuels constitute a significant proportion at 300 - 400 Megatons per year. Almost 90 % of the world's marine fuel is used by cargo ships. Passenger vessels, fishing boats, tug boats, navy ships and other miscellaneous vessels consume the remaining 10 %.

The vast majority of ships today use diesel engines similar in principle to cars, trucks and locomotives. However marine fuels differ in many aspects from automotive engine fuels.

The quality of marine fuels is generally much lower and the quality band is much wider than land based fuels. Marine engines must accept many different fuel grades often with high sulfur contents that would seriously harm the function of Exhaust Gas Recirculation (EGR) and catalyst systems on automotive engines. The viscosity of marine fuels is generally much higher ó up to 700 cSt whereas road diesel rarely exceeds 5 cSt. Most marine fuels thus require preheating to enter the fuel system.

This also means that traditional road going emission abatement technologies such as Diesel Particulate Filters, Exhaust Gas Recirculation systems and Oxidation Catalysts cannot easily be used on ships. The risk of sulfur corrosion and very high soot emissions calls for different solutions such as scrubbers or alkaline sorption systems as separate solutions or in combination with technologies known from road going emission abatement technologies.

Recent domestic and international efforts to reduce the impact of greenhouse gases (GHG) on climate change and engine emissions that affect the health of many has led international regulatory bodies such as the International Maritime Organization (IMO) and national environmental agencies to issue new

rules and regulations that drastically reduce GHG and emissions emanating from marine sources. These new rules have far reaching implications for the international shipping trade, the cruise industry, and ship owners and operators in particular. Of particular note are regulations in Emissions Control Areas (ECAs) such as the North American ECA which came into effect in 2012 and the SOx Emission Control Areas (SECA) which have been in effect in the Baltic Sea and North Sea and English Channel since 2006 and 2007 respectively. On 1 August 2012, enforcement of the North American ECA commenced. The North American ECA covers the coastal waters of the United States and Canada out to 200 nautical miles. Ships operating in the ECAs and SECAs are required to use lower sulfur fuels or add SOx exhaust scrubbers. A Caribbean ECA will come into effect for Puerto Rico and the US Virgin Islands. Allowing for the lead time associated with the IMO process, the US Caribbean ECA will be enforceable in January 2014 (Ref. 1). There is the potential that ECAs will be established for the Norwegian and Barents Sea, Mediterranean Sea, Japan, Australia, Mexico and Panama, the Arctic and Antarctica in the future (Ref. 2). The rules for these areas will mandate reductions in emissions of sulfur (S), nitrogen oxides (NOx) and particulate matter (PM). Current and possible Future ECAs are shown in Figure 1.



Figure 1. Current and Possible Future ECAs (Ref. 2)

Approximately 10% of the world's shipping is within the Baltic Sea region (Ref. 3) as shown in the following Figure 2.



Figure 2. North European SECA Effective from August 11th 2007 – (Ref. 4)

Some of the regulatory and competitive challenges facing ship operators are shown in Figure 3.

Elements in Figure 3 are sometimes competing against each other, especially considering the reduction of NO_x, Sulphur and CO₂. As an example a reduction of sulphur by use of a wet scrubber causes a significant power increase to pump water, which in the end will cause an increase in CO₂ emissions as well as other pollutants associated with the power production. NO_x could be reduced by lowering the combustion temperature, which reduces efficiency of the main engine and hence increases CO₂ and sulphur emissions. An SCR installation to reduce NO_x uses chemicals, which also have a penalty on CO₂ and environment, which should be taken in to consideration.

Possibilities to reduce emissions are influenced by the freight rates the shipowner can obtain and the fuel prices and taxes of the market. The dilemma is therefore an incentive to increase efficiency and thereby lower fuel consumption of ships.

Short term local (SECA/ECA) NO_x and SO_x reductions are the most pressing issues. On the longer term GHG and PM emissions will provide further environmental challenges.

The shipping industry also faces diminishing shipping rates and a significant rise in fuel prices including taxes in the form of Market-based measures (MBMs) for reduction of GHG emissions. Acquisitions or takeovers are common in the marine sector. A ship operator faces the risk of takeover by competitors if they are not sufficiently strong. There is a risk that operators focusing too much on environment will be taken over by stronger competitors (Ref. 5).

In particular freight rates in 2011 and at the beginning of 2012 were often at unprofitable levels for ship owners. Substantial freight-rate reductions were reported within the dry bulk, liquid bulk, and containerized cargo segments. Vessel oversupply continued to be a driving factor behind reductions in freight rates. Ship operators attempted to make savings through greater economies of scale by investing in large capacity ships in the tanker and dry bulk market segments (Ref. 6).

Incentives in the form of Market-based measures (MBMs) for the reduction of GHG emissions from international shipping could result in a fuel levy (Tax). The international shipping industry has indicated a preference for the fuel levy rather than an emissions trading scheme (Ref. 6).

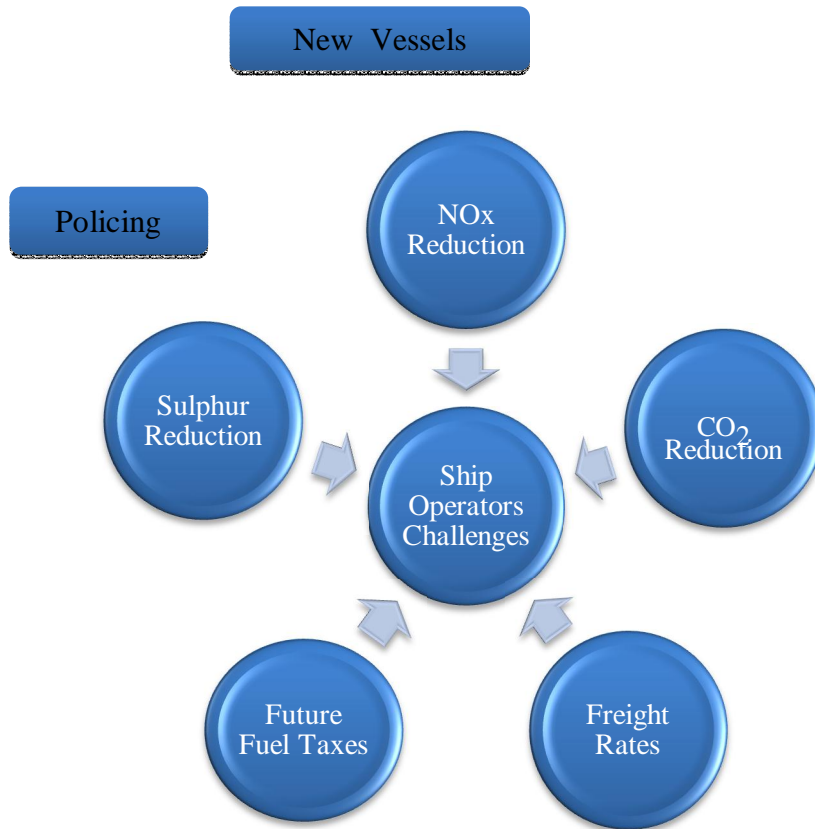

Figure 3. Ship Operator’s Challenges

Many ship operators with present day propulsion plants and marine fuels cannot meet these new regulations without installing expensive exhaust aftertreatment or switching to low-sulfur diesel, low sulfur residual or alternative fuels with properties that reduce engine emissions below mandated limits, all of which impact the bottom line profits. The impact of these new national and international regulations on the shipping industries worldwide has brought alternative fuels to the forefront as a means for compliance. The alternative fuels industry has grown dramatically for both liquid and gaseous fuels. Each of these alternative fuels has advantages and disadvantages from a shipping industry standpoint. It is vitally important that the nations recognize the impact the new marine regulations will have on their marine industries and implement policies that will minimize these impacts and pave the way for smooth transitions to alternative marine fuels and operating procedures that will meet GHG and emissions limits without jeopardizing international maritime trade.

3. Current Situation

Worldwide, marine fuel accounts for 20% of the total fuel oil demand (Ref. 7), noting that fuel oil is excluding gasoline. Currently global annual marine fuel demand is greater than 300 megatons and consists of both distillate and residual fuels. A large part of the marine fuel consumption (approximately 77%) is low quality, low price residual fuel also known as (a.k.a.) heavy fuel oil (HFO) which tends to be high in sulfur and is almost entirely consumed by large cargo carrying ships. The average fuel sulfur content of HFO used today for marine diesel engines is 2.7% with a maximum allowable limit of 4.5% (Ref. 8). See Figure 12 for average fuel sulfur limits. The fuel must also be heated to lower the viscosity so it flows easily and put through purifiers and filters to remove contaminants before it is pumped to the diesel engines.

3.1 Legislation for Marine SOx Reduction

New and existing regulations affecting the SOx emissions from ships are summarized in Table 1.

Table 1. MARPOL Annex VI Marine SOx Emission Reduction Areas with Fuel Sulfur Limits

European SECAs	Year	Fuel Sulfur (ppm)	Fuel Sulfur (%)
North Sea, English Channel	Current Limits	10,000	1
	2015	1,000	0.1
Baltic Sea	Current Limits	10,000	1
	2015	1,000	0.1
North American ECAs			
United States, Canada	2012	10,000	1
	2015	1,000	0.1
Global	2012	35,000	3.5
	2020*	5,000	.5

* Alternative date is 2025, to be decided by a review in 2018

3.2 Legislation for Marine NOx Reduction

In addition to having to meet the fuel sulfur limits in the previous table, ships operating in the ECAs must meet the MARPOL Annex VI Marine Tier III NOx limits in 2016.

Table 2 (Ref 9) shows the applicable NOx limits for ships and the dates that they are effective.

Table 2. MARPOL Annex VI NOx Emission Limits

Tier	Date	NOx Limit, g/kWh		
		n < 130	130 ≤ n < 2000	n ≥ 2000
Tier I	2000	17.0	$45 \cdot n^{-0.2}$	9.8
Tier II	2011	14.4	$44 \cdot n^{-0.23}$	7.7
Tier III	2016*	3.4	$9 \cdot n^{-0.2}$	1.96

* In NOx Emission Control Areas (Tier II standards apply outside ECAs).

NOx emission limits are set for diesel engines according to the engine maximum operating speed (n, rpm), as shown in Table 2 and presented graphically in the following Figure 4. Tier I and Tier II limits are global, while the Tier III standards apply only in the NOx Emission Control Areas (ECAs). Tier III NOx limits will apply to all ships constructed on or after 1 January 2016, with engines over 130kW that operate inside an ECA-NOx area.

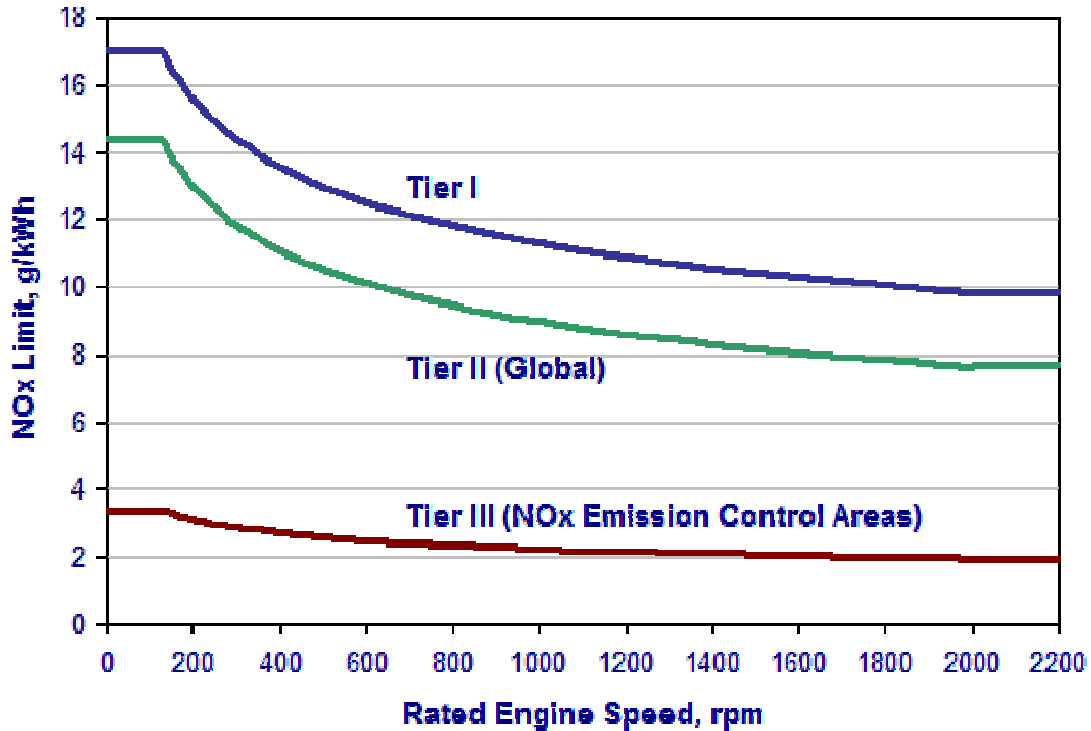

Figure 4. IMO Diesel Engine NOx Emission Limits

3.3 Compliance with Marine SOx and NOx Legislation

Given the proliferation of the ECAs and the possibilities that more ECAs may come into force in the future such as for the Mediterranean Sea and the coast of Mexico there is a strong incentive for ship owners and operators to explore the use of Alternative fuels to satisfy the lower fuel sulfur and NOx limits.

Another approach for meeting the NO_x and SO_x limits is to install emission compliant engines or Selective Catalytic Reduction (SCR) equipment for NO_x reduction and exhaust aftertreatment devices know as scrubbers for SO_x reduction. When looking at these technologies the cost tradeoff for their installation, operation, and maintenance versus the cost of the alternative fuel must be considered.

This report only deals with fuels which are suitable for heavy duty diesel engines providing propulsion and auxiliary energy on commercial ships which is the bulk of marine fuel consumption.

Turbine engines are rarely used on commercial ships. Part of the reason is that gas turbines are generally costly and less efficient than diesel engines and therefore less suited for commercial use. The same goes for spark ignition (SI) engines. Steam turbines are extremely fuel flexible, but also slow starting. Furthermore they require a rather steady load in the high band, which is why they are not common. Other fuels not included for practical, economical or safety related limitations of ships are:

- Nuclear fuels
 - Thorium
 - Uranium
 - Plutonium
 - H₃
- Wind or solar power
 - Sails
 - Kites
 - Wind turbines
 - Photo voltaic cells
- Solid boiler fuels
 - Coal
 - Coke
 - Peat
 - Lignite
- Gas turbine or SI engine specific fuels
 - Kerosene
 - Ethanol
 - Gasoline
- Gasification fuels
 - Wood and other cellulosic biomass
 - Sludge and other organic wastes
- Electro chemical fuels
 - Hydrogen
 - Batteries

A distinction should be made between ***drop-in fuels*** as defined in Section 5 which can be distributed through existing channels and non ***drop-in-fuels*** which require a completely new infrastructure. Marine

fuels in particular should be available everywhere in the World. For this reason particularly rare and exotic fuels are not included in this discussion of future marine fuels.

4. Fuel Prices and Availability

This section examines the cost and availability of marine fuels.

Current marine fuels (World Market) - There is some uncertainty to the global marine fuel consumption. The variation between studies suggests a possible range between 279 - 400 Megaton/year. Based on several studies IMO estimates the total 2007 fuel consumption at 333 Megaton/year (Figure 5).

26 Second IMO GHG Study 2009

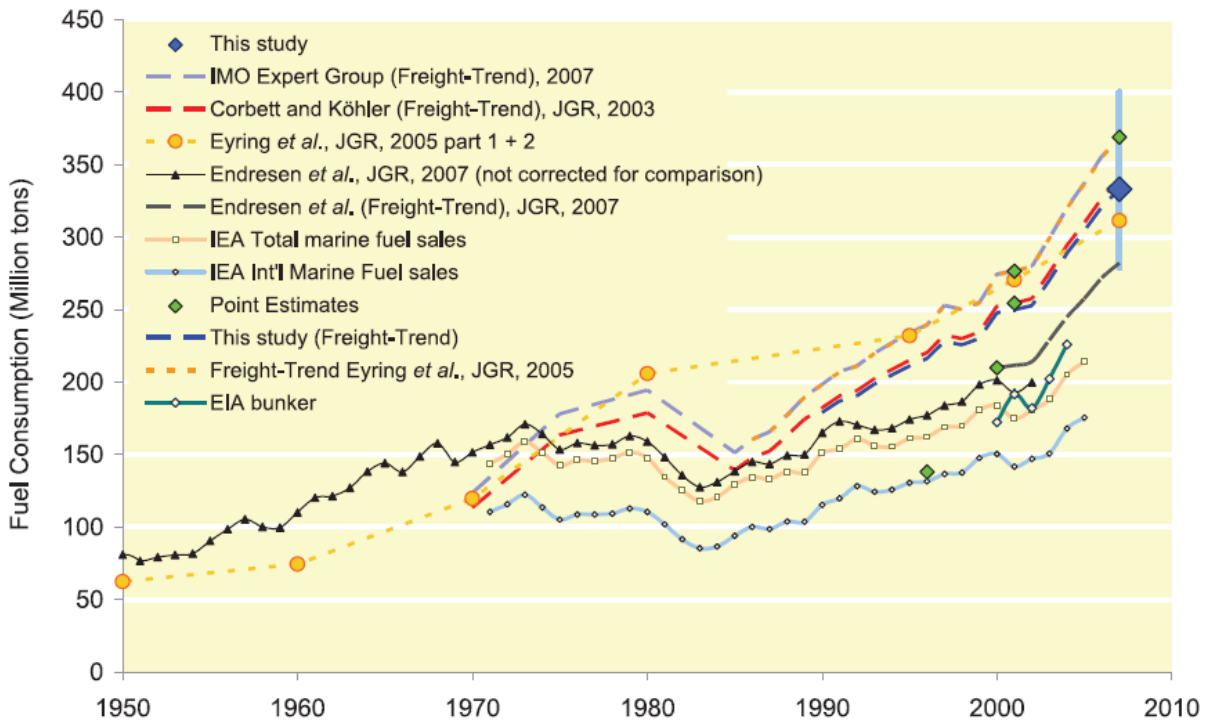

Figure 5. Global Marine Fuel Consumption Estimates, IMO 2009 (Ref. 11)

Marine fuel standards are set in ISO 8217. There are 10 grades of residual fuel of which 380 and 180 are the most common.

IMO estimates that 77 % of all marine fuel (257 Megaton/year) is residual fuel (RFO). High sulfur RFO use is concentrated on the largest long-haul vessels (Ref. 10).

Figure 6 shows a typical fuel mix sold in one of the world's busiest seaports (Singapore).

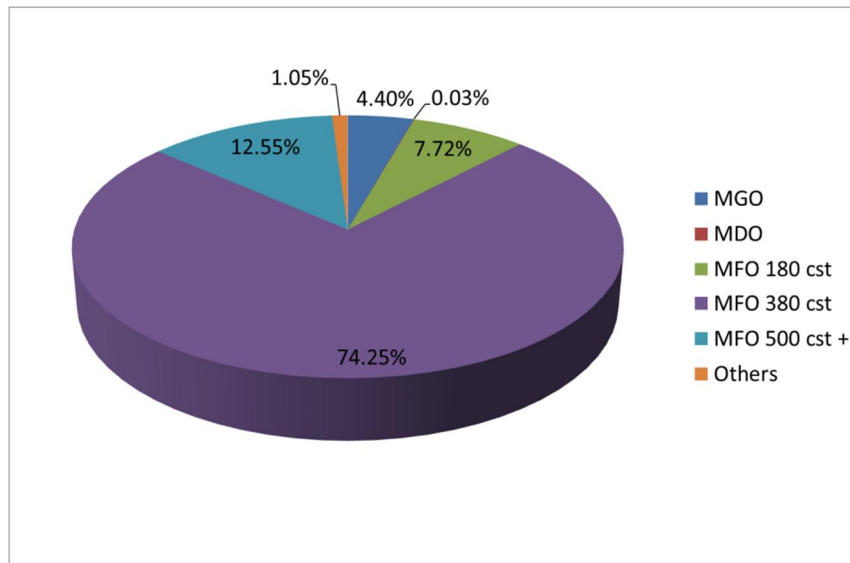

Figure 6. Typical Heavy Marine Fuel Type Distribution

(Singapore Port Bunkering Statistics 2009,

http://www.mpa.gov.sg/sites/port_and_shipping/port/bunkering/bunkering_statistics/bunker_sales_volume_in_port.page)

Since the Singapore Port sells practically no MGO or MDO it will be assumed that the distribution is valid for heavy fuels only i.e. 77.2 % of the market. Distillate fuels shall add up to 22.8 %. The resulting fuel statistics, including lighter fuel types not sold in Singapore is shown in Figure 7.

Fuel type	Other names	Market per cent	Megaton per year
Heavy fuel 500 CSt	HSFO 500 CSt, RFO, RMG500,IFO500,MFO500	10%	33
Heavy fuel 380 CSt	HSFO 380 CSt, RFO, RMG380,IFO380,MFO380	60%	200
Heavy fuel 180 CSt	HSFO 180 CSt, RFO, RMG180,IFO180,MFO180	6%	20
Distillate fuels	Diesel, Marine diesel, MGO, MDO, LFO	23%	77
Others		1%	3
Total		100%	333

Figure 7. Global Marine Fuel Use Estimated from IMO and Singapore Port Bunkering Statistics 2009

Global Fuel consumption by Vessel type - IMO estimates the total world fleet to be 100,243 vessels above 100 GT (Ref. 11). The fleet consists of approx. 40% cargo ships 20% tankers and 25% container ships according to DNV (Ref. 12). See Figures 8 and 9.

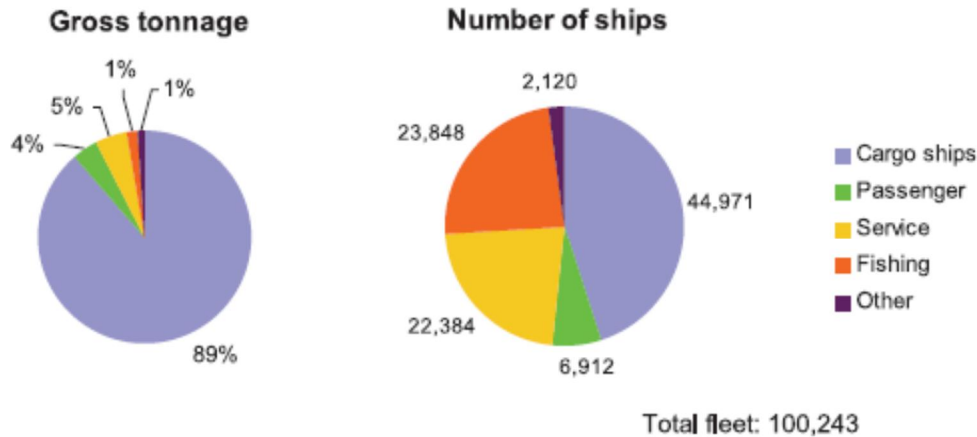

Figure 2.5 Composition of the world fleet [Lloyd's Register – Fairplay, 2007]

Figure 8. The Total World Marine Fleet According to IMO (Ref. 11).

Only 25 % of the vessels run on RFO, however they account for 77 % of global marine fuel consumption.

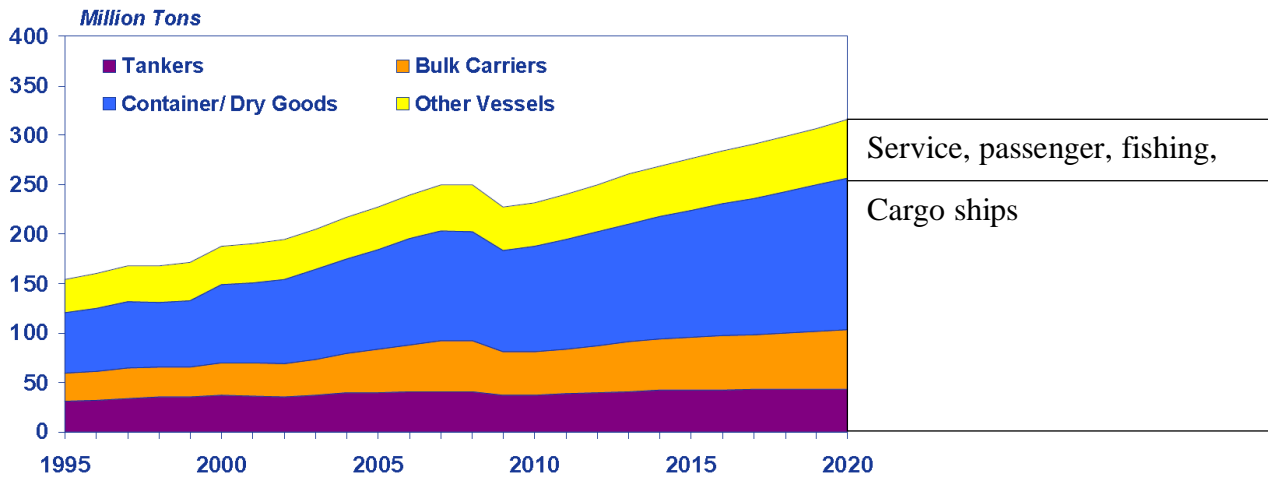

Figure 9. World Bunker Fuel Demand (Ref. 10)

Fuel cost - High viscosity High Sulfur Fuel Oil (HSFO) is the least costly fuel, whereas lighter fuels with less sulfur generally raise the cost. Baseline for HSF380 is about \$700 USD/ton. Marine diesel MDO (or MGO) are about \$1,000 USD/ton. Figure 10 shows index prices from Bunkerworld.

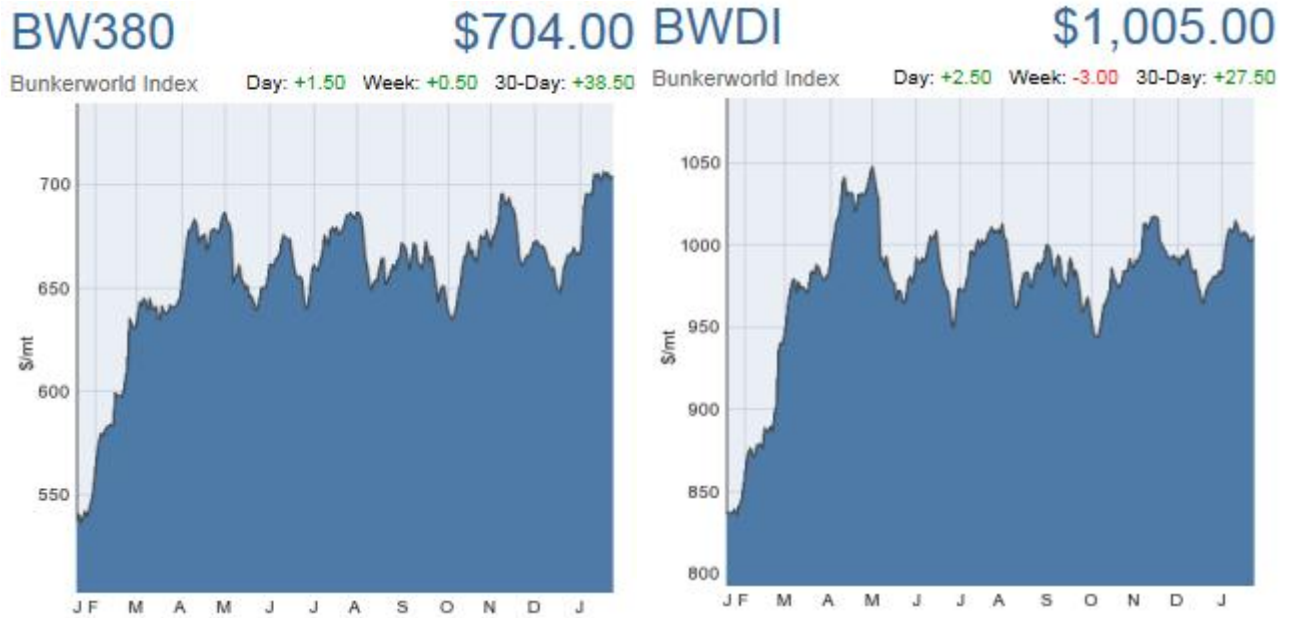

Figure 10. Bunkerworld Index Prices of HFSO380 and MDO

The on-cost of different light fuels are somewhere between \$100 and \$400 USD/ton as shown in Figure 11. The difference varies with time.

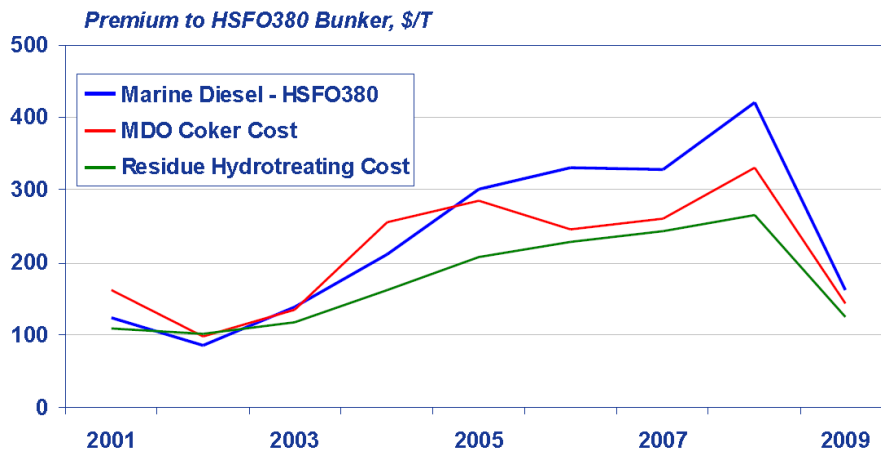

Figure 11. Cost of Lighter Low Sulphur Fuels Compared to High Sulphur Bunker Fuel (Pervin&Gertz)

World LNG prices are in the range of 0.05 EUR/kWh. This corresponds to about \$1,000 USD /ton, which is comparable to light fuel (MGO or MDO). However LNG typically holds 20-25 % more energy per ton compared to MDO so the price is attractive.

5. Alternative Marine Fuel Incentives

Currently there are a number of incentives for using alternative fuels. These are:

- The MARPOL Annex VI SO_x and NO_x legislation discussed in Section 2
- Price fluctuations of Fossil Fuels
- Prediction of a diesel fuel shortage in Europe (Ref. 13).
- Possible scarcity of lower sulfur distillate fuel in 2015 when the switch from 1.0% to 0.1% Sulfur requirement takes effect (Ref. 2)
- The proliferation of ECAs with the possibility that future ECAs may come into force in the Mediterranean Sea and off the coast of Mexico and Singapore which has asked for an ECA.
- Current Emission Control Areas (ECAs) with their SO_x and NO_x limits
- In the United States the Renewable Fuels Standard (RFS) requiring a certain amount of renewable fuels as part of the available fuel inventory.
- The introduction by IMO in MARPOL Annex VI of the Energy Efficiency Design Index (EEDI) which would make mandatory, measures to reduce emissions of greenhouse gases (GHGs) such as CO₂ from international shipping. The EEDI standards phase in from 2013 to 2025. The EEDI creates a common metric to measure and improve new ship efficiency. This metric is calculated as the rate of carbon dioxide (CO₂) emissions from a ship.

Alternative fuels that can help satisfy the above requirements and with certain attributes can possibly be substituted for the fossil fuels currently in use. These alternative fuel characteristics are:

- Ideally should not have a major impact on the engine and ship board fuel systems such that they must be extensively modified or replaced.
- There is no degradation of engine performance such as to require engine replacement or extensive modification.
- The fuel lowers the engine SO_x and NO_x Emissions
- It is competitively priced with the current Heavy Residual Fuel Oil price of approximately \$700 (USD)/ Ton (Ref. 14).
- The alternative fuel is available in sufficient quantities worldwide or regionally for bunkering.
- It can be mixed with current fossil fuels.
- It is safe to use and does not present any major environmental risks.

A fuel satisfying these requirements is called "a drop in fuel".

In addition to regulatory and monetary incentives for alternative fuels the Trans-European Transport Network Executive Agency has taken action called the 2011-EU-92079-S Project to identify and minimize the barriers when building and operating an LNG fueled vessel (Ref. 15).

The project was selected for funding under the 2011 TEN-T Annual Call, and will examine the technical requirements, regulations and environmental operation permits that need to be met in order to shift from traditionally fueled engines to LNG. LNG is rapidly emerging as a cheaper and more environmentally friendly fuel for the maritime sector and its uptake is encouraged by the European Union.

Specific aspects related to the manufacturing, conversion, certification and operation phases of a LNG fueled vessel will be analyzed. These results will be exchanged with other ongoing LNG-related projects as well as with the European Maritime Safety Agency. The project will be implemented in a partnership with stakeholders consisting of ship-owners, cargo owners, LNG suppliers, ports and marine equipment manufacturers. Among shipowners participating will be Viking Line operator of the 2,800 passenger dual fuel cruise ferry the ðViking Graceö.

The project will get þ1.2 million of European Union funding under the TEN-T program. This contribution constitutes 50% of the overall budget.

The project will be managed by the Trans-European Transport Network Executive Agency and is set to be completed by the end of 2014 (Ref. 16).

6. Alternative Marine Fuels and Engines

Currently there are liquid fossil fuels, liquid biofuels and gaseous fuels that are in use or can be used by ships for compliance with the existing and forthcoming environmental air pollution requirements.

The feed stocks for the current and future marine fuels are shown in Table 3. Of these; Biodiesel (FAME), Methanol, Algae and HDRD are considered viable alternative marine fuels and are discussed in detail in Section 6.3.

Table 3. Feedstocks and Derived Fuels

Feedstock			
Natural gas, Bio-Gas	Crude Oil	Vegetable Oils, Animal Fats, Algae Lipids	Biomass
Fuels			
CNG, LNG	IFO, LSFO, LPG, MGO	Biodiesel(FAME), HDRD (Second Generation Biodiesel)	BTL, GTL, Methanol, DME, Pyrolysis Oil, LBG

There are liquid bio and fossil fuels that are low in sulfur and can satisfy the fuel sulfur requirements of the ECAs and MARPOL Annex VI. In lieu of using low sulfur fuels the use of scrubbers fitted in the engine exhaust to remove the SOx is another option.

The Effship Project investigates methanol and Dimethyl Ether (DME) as alternative fuels in WP 2 (Ref. 17). The fuel options mentioned are LNG, Methanol, DME and Gas to Liquids (GTL). However no conclusion has yet been reached.

MAN Diesel & Turbo electronically controlled, gas injected, low speed ME-GI engine types are available in dual-fuel versions with the LPG-fueled version designated ME-LGI (Ref. 18). The Liquid ME-GI engine's performance is equivalent in terms of output, efficiency and rpm to MAN Diesel & Turbo's ME-C and ME-B series of engines. As the Liquid ME-GI engine's fuel system has few moving parts, it is also more tolerant of different fuel types and accordingly can run on DME. It can burn gas or fuel oil at any ratio depending on the fuel aboard and the relative fuel cost and it operates with no methane slip.

Dual fuel systems are available both for Methanol and LPG (propane dual fuel, Ref. 19).

6.1 Liquid or Crude Based Fossil Fuels (IFO,LSFO,MGO and MSAR2 Bunker Oil)

According to IMO (Ref. 20) about 77 % of total marine fuels used globally are residual fuels (IFO). LSFO and MGO are used as secondary fuels for compliance with ECA and SECA restrictions.

Along with global warming potential sulfur content remains the main concern with conventional marine fuels. The sulfur content is generally high compared to road fuels as shown in Figure 12. According to DNV the total SO₂ emission from ships is about 130 kilo-ton per year.

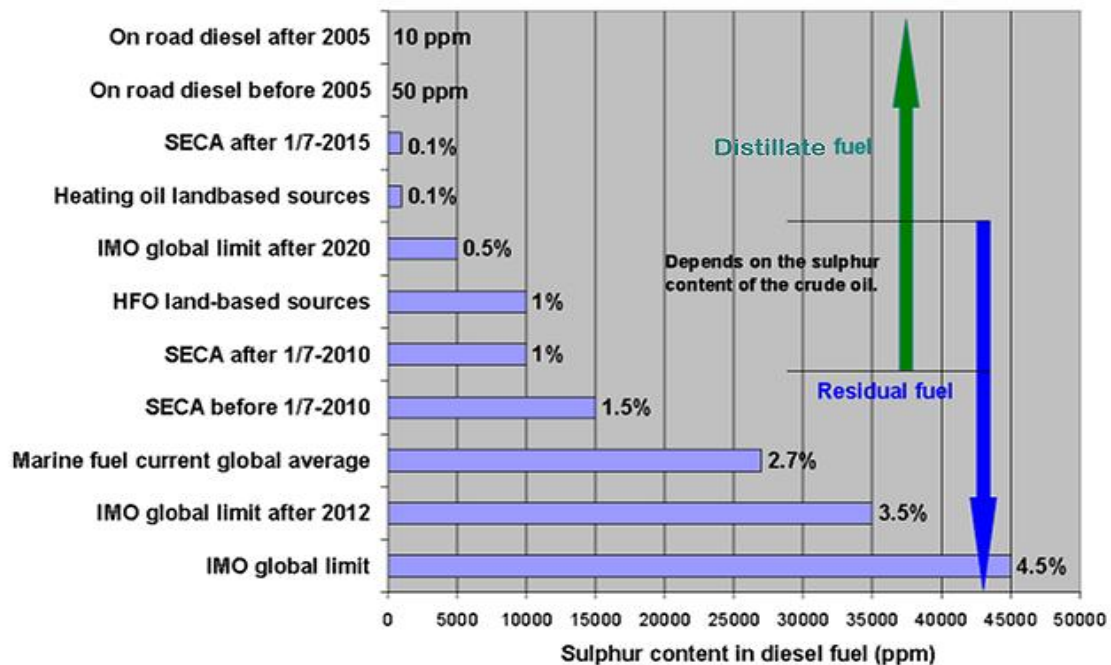

Figure 12. Sulphur Content of Conventional Marine Fuels (Ref. 4)

The emissions of both sulfur and other pollutants can also be effectively reduced by boosting the efficiency of the propulsion system. It is worth mentioning that marine transport on large container ships

only requires 2 to 3 grams of fuel per ton*km (Maersk Line average). Road transport by truck requires about 15 g/ton*km (global average).

Some conventional means of efficiency boosting may be very effective. For instance the anticipated Mærsk Triple-E ships offer 50% CO₂ reduction by means of +16% container capacity, -19% engine power and -2 knots lower design speed (Ref. 21).

Existing ships such as the Emma Maersk have turbo-compounding and other technologies to increase total efficiency.

Fossil fuels that are available for marine use are Ultra Low Sulfur Diesel (ULSD) fuel which is the term used to describe diesel fuels with substantially lower sulfur content and Low Sulfur Residual Fuel (LSRF). For ULSD the amount of sulfur can vary from country to country. For example in the United States and Canada it is 15 ppm and in other countries it can be as low as 10 ppm and high as 50 ppm. Not all countries require that marine diesel be ULSD but in the US and Canada ULSD is required for marine diesel fuel as well as over the road and off road diesel powered vehicles. As of 2006, almost all of the petroleum-based diesel fuel available in Europe and North America is of a ULSD type.

Low Sulfur Residual Fuel (LSRF) is another fossil fuel that can satisfy the current requirements for low fuel sulfur content. Low Sulfur Residual Fuel (LSRF) can be produced by; 1) the refinery processes that removes sulfur from the oil (hydrodesulphurization), (2) blending high-sulfur residual oils with low-sulfur distillate oils, or (3) a combination of these methods.

It is conceivable that these fuels will suffice for the marine industry for low sulfur fuels until 2016 when the NO_x requirements are effective. At this time the use of these fuels will require the installation of NO_x aftertreatment devices such as Selective Catalytic Reduction (SCR), Exhaust Gas Recirculation (EGR), or the installation of emission complaint engines to satisfy the NO_x limits within the ECAs.

It is possible conventional fossil based fuels will remain the fuel of choice for a long time. IMO projects in different scenarios a rather low penetration of alternative fuels, ranging from 5-10 % (tank ships ó coastwise respectively) in 2020 to a maximum 20-50 % (tank ships - coastwise respectively) in 2050 (Ref. 20). Thus fossil fuels are predicted to be predominant in the foreseeable future.

Maersk successfully tested a low-cost alternative to heavy fuel oil called MSAR®2 (MulPphase Superfine Atomized Residue) bunker oil using a 2-stroke marine diesel engine of a Maersk Line container ship, an engine fairly typical of a type to be found on modern ships. The tests were carried out in late 2012.

Quadrise, the innovators of this Marine MSAR®2 bunker oil anticipate that commercial volumes will be produced progressively from mid-2013, with a full commercial roll-out the following year.

Quadrise was formed in the 1990s by a group of former BP specialists who developed new technology to produce MSAR®, from a variety of heavy hydrocarbons with superior combustion characteristics. In 2004 a long term alliance agreement was established with AkzoNobel, a world leader in surface chemistry.

MSAR® Fuel Technology renders heavy hydrocarbons easier to use by producing a low viscosity fuel oil using water instead of expensive oil-based diluents, and also produces a superior fuel with enhanced combustion features.

The process involves smaller fuel droplets in a stable water-based emulsion being injected into the cylinder, resulting in a complete combustion that produces lower NOx and PM exhaust gas emissions.

Besides the low-cost benefits it offers to shipowners as a heavy oil bunker fuel, the new technology helps oil refiners as it frees up valuable distillates traditionally used for HFO manufacture, providing a viable alternative process for handling the bottom of the crude oil barrel without significant expenditure resulting in increased profitability.

The MSAR® process transforms hydrocarbons that are solid at room temperatures (and have to be heated to temperatures over 100°C in order to flow) into a product that can, depending on client requirements, be stored and transported at ambient temperatures of 15-30°C. As a result the energy requirements for handling and transporting MSAR® are lower than HFO, which is generally handled at temperatures in excess of 50°C.

MSAR® fuel can be handled using the same equipment and vessels used for conventional HFO. Operating procedures and contingency plans developed for HFO are generally suitable, and where necessary adapted, for MSAR® purposes (Ref. 22).

6.2 Liquid Biofuels (Fuels from vegetable oils and animal fats, straight, hydrogenated or esterified)

Liquid biofuels available for marine use are Biodiesel, (Fatty Acid Methyl Ester (FAME)), Algae Fuels, Methanol, Hydrogenation-Derived Renewable Diesel (HDRD) which is also known as second generation biodiesel, and pyrolysis oil.

Soy bean oil has been used by the Mols Linien (Ferry line) in Denmark. Fish and chicken oil has also been tested.

The potential for oils and fats has been exploited for years by the automotive sector, so it is questionable how much potential actually remains. Drawbacks of these fuels are limited miscibility with IFO fuel, sensitivity to frost and the problem of conservation.

Biodiesel (FAME), Algae fuel, Methanol, HDRD, and pyrolysis oil are virtually sulfur free. The Algae and HDRD fuels are compatible with diesel engines and their associated shipboard fuel systems. Biodiesel (FAME) is not compatible with certain non-metallic and metallic materials and usually requires modification of current engines and shipboard fuel systems. Pyrolysis oil is high in acidity, has a low cetane number, is practically sulfur free and is not mixable with diesel fuel so must be modified for marine use (Ref. 23).

FAME is a well-known and proven blending component for road going diesel machines but has not found its way into use as a marine fuel.

Within the ISO 8217 framework FAME is currently being adapted as a blending component for heavy marine fuel. It is foreseen that a volume concentration of up to 7 % will be allowed in the near future.

Fatty Acid Methyl Esters are a refined version of vegetable oils or animal fats. They are common in road transport and have also been used in Denmark by M/F Bitten Clausen until March 2011. The project was successful with a blend of 25 % animal based FAME.

FAME in general does not cause any problems in the engine itself. Long term storage however can be problematic. Tank paint and engine gaskets, hoses, non-metallics and some metallic fuel wetted parts may need to be adapted to FAME.

The main problem with FAME is sustainability since FAME production relies heavily on palm oil production which is often in conflict with the preservation of natural rain forests. Therefore FAME is generally not seen as a viable long term option.

In addition to the sustainability problem the use of FAME in some U.S. marine applications has not been successful. The US Navy prohibits the use of FAME biodiesel since they use water to displace the fuel in their shipboard tanks for ballast and have centrifugal purifiers on board to separate the fuel and water. FAME causes a huge emulsion and does not allow the fuel to be separated from the water. FAME is corrosive to metal surfaces once it mixes with water and the mixture falls out. The United States Coast Guard had microbial growth problems on one of their cutters in Duluth, Minnesota when they lifted a 2% blend of FAME Biodiesel. The problem prevented the vessel from sailing. The tanks had to be emptied, cleaned and the vessel refueled with FAME free diesel fuel. The cutter now procures the fuel before the mandatory blend to avoid fuel quality issues (Ref. 24).

Methanol - Methanol as a general fuel has been recommended by CEESA ó an interdisciplinary research cooperation from Denmark. The reason is that biomass to methanol/DME is foreseen to be the most energy efficient pathway to transport energy in 2050.

Conversions of marine vessels to methanol are significantly less costly than conversions to LNG due to the simplicity of the storage system for methanol. While Methanol itself is slightly more costly than LNG the trade-off between methanol and LNG is the complexity of the fuel system versus the cost of the fuel.

Methanol increases the risk of corrosion which must be met with sufficient upgrading of fuel tanks, etc. and the low energy content per cubic meter (m^3) of methanol takes up cargo space on the ship.

Methanol has similar properties to methane, when injected in an engine. It can be used in a dual fuel concept, as proposed by Wärtsilä (Figure 13).

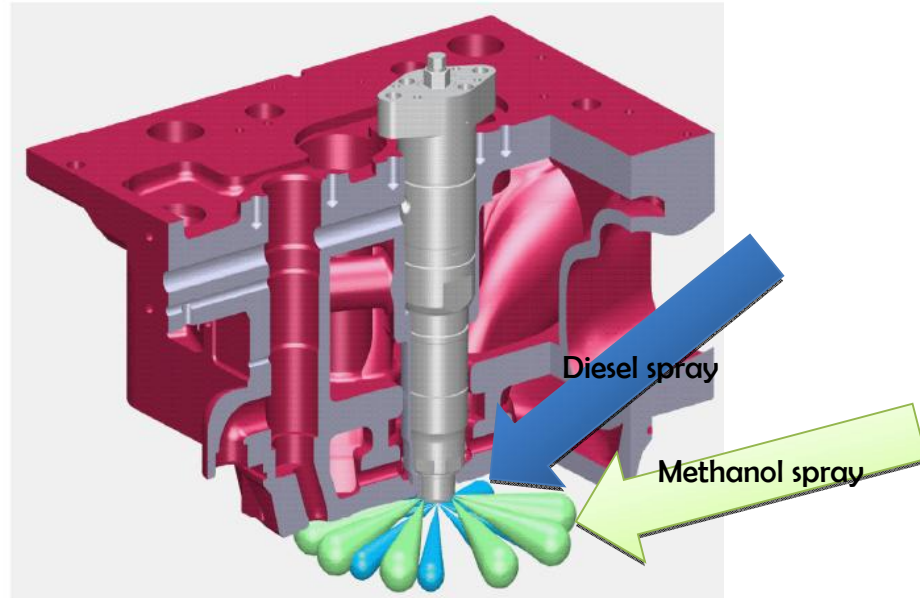

Figure 13. Wärtsilä Direct Injection Dual Fuel Concept for Methanol in Large Four Stroke Engines

Bio crude (pyrolysis oil) - Bio crude such as the German bioliqSynCrude® is an intermediary pyrolysis oil produced from e.g. the CatLiq™ process. The feedstock can be either solid biomass or sludge. Like fossil crude bio crude can also be refined into gasoline or diesel-like products. However bio crude in its initial form is perhaps the cheapest liquid biofuel possible.

The main challenges are:

- Low cetane number
- High water content
- Poor lubricity

However, the use of bio crude as a feasible marine fuel is yet to be proven.

6.3 Gaseous Fuels

Gaseous fuels available for marine use are Natural Gas and Propane (LPG). These fuels are not only very low in sulfur content they combust such that NO_x, PM, and CO₂ are reduced. Natural gas can be carried in a compressed state called Compressed Natural Gas (CNG) or in a liquid state called Liquefied Natural Gas (LNG).

Propane or LPG is mentioned from time to time as a marine fuel. However there seems to be very limited material available on the potential for LPG as a marine fuel. The general view globally seems to be that LPG is a premium product and as such priced accordingly and is too expensive compared to other alternative fuel options. The supply is there, but current markets are automotive transportation and domestic heating and cooking, markets that have a different price reference than shipping.

Safety wise propane is heavier than air and as such presents an explosive safety hazard of accumulating in the bilges or low sections of the ships engine room if there is a leak in the fuel system and is not considered safe for shipboard use.

CNG is made by compressing to less than 1% of the volume it occupies at standard atmospheric pressure. It is stored and distributed in containers at a pressure of 2006248 bar (290063600 psi), usually in cylindrical or spherical shapes.

LNG achieves a higher reduction in volume than CNG. The liquefaction process condenses the natural gas into a liquid at close to atmospheric pressure by cooling it to approximately 162 °C (260 °F). The energy density of LNG is 2.4 times that of CNG or 60% of that of diesel fuel. This makes LNG attractive for use in marine applications where storage space and endurance are critical.

The natural gas for CNG and LNG can also be derived from renewable bio-gas and is sometimes called bio methane

LNG is one of the most promising alternative marine fuels. It takes up about 1/600th the volume of natural gas in the gaseous state. Hazards include flammability, freezing (163 °C (260 °F) and marine regulations that require extra safety precautions like double wall piping, gas detections systems etc. in engine rooms.

There is already an established LNG infrastructure in Norway (for short sea shipping). In the fall of 2011, 26 LNG ships were reported in operation in Norway (Ref. 25), 15 are ferries. Another 15 LNG ships are under construction. In Poland 2 dual fuel LNG ships are being built for the ferry company Fjordline.

It is sometimes suggested that about half the commercial fleet of marine vessels could be converted to LNG. However these would not be the largest vessels, since the range would probably not satisfy ocean going ships. Thus in term of fuel amount the proportion would be *much* less than half the fleet. It has been estimated that there will be a consumption of 2.4 Megatons LNG in 2020 (Ref. 26). This corresponds to less than 1 % of global shipping.

For economic reasons LNG conversions generally require that 30 - 40 % of the operation is within ECA areas. Otherwise the capital investment will be too heavy (Ref. 19).

A major concern with LNG is the possibility for de-bunkering (emptying the fuel tanks). This is necessary when the ship is to be anchored for an extended period of time. Unless special LNG de-bunkering facilities are available in the port the gas would boil off causing huge methane losses to the atmosphere. In case of grounding accidents a technique for de-bunkering would also be necessary. Another concern is pressure increase do to consumption below the natural boil-off rate, which will happen if there is no re-liquefaction plan available onboard. Re-liquefaction of boil-off gas will require about 0.8 kWh/kg gas. One large LNG carrier, such as Qatar Q-max LNG carrier, requires 5-6 MW of re-liquefaction power, corresponding to 8 tons/hour boil off.

A third concern to be addressed is methane slip from larger marine engines burning gas. Methane slip will be present, especially on four stroke Dual Fuel engines (Fig 14), partly from the scavenging process

in the cylinder and partly from the ventilation from the crank case, which is being lead to atmosphere. Also there is some uncertainty as to whether future regulations will allow LNG tanks to be situated directly below the outfitting/accommodation of the ship. If not this could cause difficulties in retrofitting certain ships.

LNG is chemically identical to bio methane. Bio-methane is generally known to be the most CO₂ friendly fuel of all (Ref. 27). Recent activities in the area belong to Holland Innovation Team and Anglo Dutch Bio-LNG. See (Ref. 28).

Biogas requires dual fuel technology for the marine engine, and extra storage facilities, either as pressure tanks or cryogenic tanks for Liquefied Bio Gas (LBG). Biogas is usually produced from inland bio waste and thus is challenged on transportation cost to marine vessels.

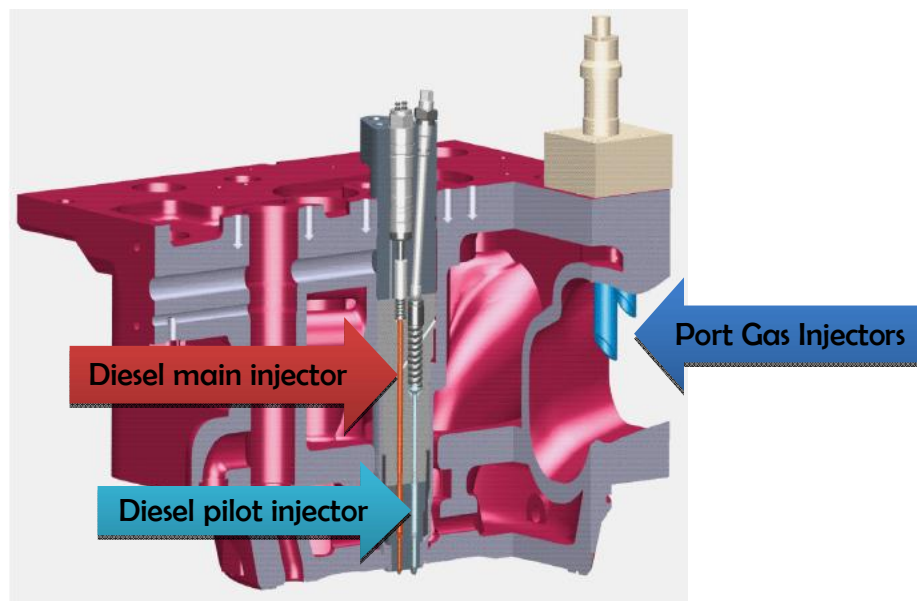

Figure 14. Wärtsilä Port Injection Dual Fuel Concept for Gas Use in Large Four Stroke Engines

6.4 Exhaust Gas Treatment Systems (EGTSs)

An alternative to using low sulfur fuels for reducing the SO_x emitted in the exhaust is to clean the exhaust gas using scrubber technology. This technology is proven for shore side power stations worldwide. These systems can clean the exhaust to the SO_x level that is equivalent to the required fuel sulfur content. Using a SO_x scrubber offers the flexibility of using a low sulfur fuel or higher sulfur fuel. The scrubbing efficiencies of SO_x scrubbers presented in (Ref. 8) are:

- PM Trapping ó greater than 80%
- SO_x removal ó greater than 98%

SOx scrubbers are classified as wet or dry.

- Wet - Use water (seawater or fresh) as the scrubbing medium
- Dry - Use a dry chemical such as calcium hydroxide.

Wet systems are further divided into:

- Open loop systems that use seawater.
- Closed loop systems that use fresh water with the addition of an alkaline chemical;
- Hybrid systems which can operate in both open loop and closed loop modes.

For a comparison of the systems see Section 6.8 and Table 3 of (Ref. 29) the Lloyd's Register publication, "Understanding Exhaust Gas Treatment Systems, Guidance for Shipowners and Operators, June 2012". This publication also provides a detailed discussion of SOx scrubbing and NOx abatement systems as well as two case studies performed on two ferries, the Pride of Kent and the Ficara Seaways.

Based on a 2009 plan using a SOx exhaust scrubber that was installed on a Det Forenede Dampskibs-Selskab (DFDS) passenger car ferry it was estimated that the payback period could be as low as two years. The plan is to operate the scrubber in the high efficient sodium hydroxide (NaOH) mode in coastal waters and in saltwater mode in the open sea where lower sulfur scrubbing efficiency is sufficient (Ref. 8).

Only a few ships are operating with SOx scrubbers or have ordered them and many of these are on a trial basis. Royal Caribbean Cruise Lines has contracted with Wärtsilä Hamworthy for the installation of four hybrid scrubbers for their two new "Sunshine" class vessels after an earlier pilot installation aboard their "Liberty of the Seas". The first vessel is due for delivery in autumn 2014 and the second in the spring of 2015 (Ref. 30). Exhaust gas SOx scrubbers by Green Tech Marine (GTM R 15 Scrubber) were recently installed by Norwegian Cruise Lines (NCL) in their "Pride of America". The scrubbers were installed in March 2013 during the ship's dry-docking. The small footprint and low weight of the Green Tech system is compact and no passenger or crew space is lost, the installation needs no steel work modification and the scrubber takes up about the same amount of space as the exhaust silencer it replaces. The system can operate in closed or open mode (Ref. 31). Korea's STX Offshore & Shipbuilding awarded Wärtsilä a contract to supply exhaust gas cleaning systems for four new container RO/RO (ConRo) vessels being built for Italy's Ignazio Messina & Co. The Wärtsilä systems supplied will clean both sulfur oxides (SOx) and particulate matter emissions from the main engines, auxiliary engines, and the boiler. Deliveries are scheduled to take place during 2013 and 2014, and the vessels are to be delivered by the shipyard to Ignazio Messina & Co during the second half of 2014 (Ref. 32). Great Lakes Seaway shipping line Algoma Central Marine is building six new 225 m long "Equinox-class" Lakers that will be 45% more fuel efficient than existing Lakers. They will be equipped with Wärtsilä complete propulsion packages that come with fully integrated fresh water scrubber systems (Reference 33).

Exhaust gas treatment systems for NO_x, (NO_x reducing devices) provide the flexibility to operate ships built after 1 January 2016 in ECAs designated for NO_x emission control.

Tier III NO_x limits will apply to all ships constructed on or after 1 January 2016, with engines over 130kW that operate inside an ECA-NO_x area. Unlike the sulfur limits in Regulation 14 of MARPOL Annex VI, the Tier III NO_x limits will not retrospectively apply to ships constructed before 1 January, 2016 (except in the case of additional or non-identical replacement engines installed on or after 1 January, 2016 (Ref. 29)).

For compliance with Tier II NO_x emission limits on-engine adjustments and modifications will be able to satisfy these limits. For Tier III NO_x compliance the current thinking is that either Selective Catalytic Reduction (SCR) or Exhaust Gas Recirculation (EGR) will be necessary for meeting the Tier III limits. For a detailed discussion of NO_x emission reduction technologies consult the Lloyd's Register publication Ref. 8, "Understanding Exhaust Gas Treatment Systems, Guidance for Shipowners and Operators, June 2012" at (www.lr.org/eca).

Scrubber systems are priced at about 3 Million USD. The price difference between HFO 380 and LSFO is roughly 40 USD/ton while the price premium of MGO compared to HFO 380 is about 330 USD/ton. The pay back of scrubber systems typically relies on a price difference of 200-600 USD/ton (Force presentation from CHP 22/11-2011). Scrubber system costs are shown in Figure 15.

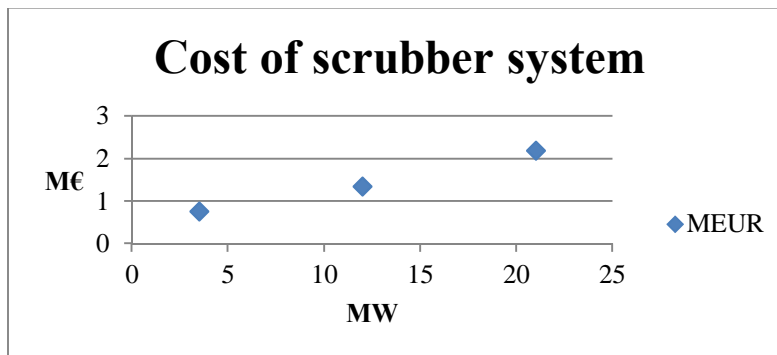

**Figure 15. Cost of Scrubber Systems [Couple Systems, Alfa Laval].
See Ref. 34 for Cost calculations.**

The problems with scrubbers are loss of cargo capacity due to the large physical size of the systems. Winter operation can also be a challenge (Ref. 35).

See Appendix A for illustrations and operational details of some exhaust aftertreatment systems provided by various vendors.

7. Assessing Alternative Fuels for Marine Use

When assessing fuels it is necessary to evaluate several parameters related to technical, economic and environmental implications of each fuel.

The considerations have been grouped into five main criteria with sub criteria.

- Engine and fuel system cost, including
 - New vessel on-cost
 - Retrofit investments
 - Increased maintenance cost
- Projected fuel cost, including
 - Projected fuel price per Mega Joule (MJ)
 - Availability and cost of infrastructure
 - Long term world supply
 - Fuel consumption penalty (e.g. due to lesser efficiency, boil off)
- Emission abatement cost, including
 - PM port compliance (e.g. fuel change)
 - SO_x SECA (e.g. scrubber)
 - NO_x SECA (e.g. SCR, EGR)
 - CO₂ EEDI (e.g. slow steaming, heat recovery)
- Safety related cost, including
 - Approvals (classification)
 - Additional insurance cost
 - Crew training and education
- Indirect cost, including
 - Reduced range between bunkering
 - Reduced cargo capacity
 - Increased waiting time in ports

The following paragraphs discuss the favorable attributes and drawbacks of the marine alternative fuels in regards to their practicality and affordability for marine use.

7.1 Liquid Fossil Fuels (ULSD, LSRF) Advantages:

A. Fuel System and Engine Compatibility - These fuels are currently in use in many marine engine installations or can be used in current marine engines because of their similarity to the fuels that are in use today. The lighter ULSD or Low Sulfur Diesel (LSD) is similar to distillate diesel fuel that is used in medium and high speed shipboard diesels and on ships burning residual fuel when entering a fuel sulfur restriction zone. For ships normally burning residual fuel special procedures must be observed when transitioning to the lower viscosity distillate fuels. The diesel engine manufacturers have developed a "Smart Switch" to facilitate this operation and there are publications and bulletins available for switching to and operating on low sulfur fuels.

These fuels are compatible with current shipboard diesel engines and fuel systems. For ships that do not operate for a substantial amount of time in an ECA the owners/operators may choose to use lower sulfur fuels only when transiting an ECA. This scenario requires the installation of additional fuel tanks with associated piping and pumps for the low sulfur fuel.

B. Lower SOx Emissions - The lower sulfur levels in these fuels ensure the ship will be in compliance with the lower sulfur limits required in the ECAs and by IMO.

C. Safety - The fuels are safe to use having similar characteristics to current distillate and residual diesel fuels.

D. Availability - They are commercially available for ship bunkering. Most of the ports that currently offer high sulfur fuel oils also have available low sulfur fuel oil of the same grade.

7.2 Liquid Fossil Fuels (ULSD, LSRF) Drawbacks:

A. Price - The cleaner lower sulfur distillate and residual fuels are more expensive than the current fuels. The low sulfur residual fuels have a higher price than the high sulfur residual fuels due to the cost of the desulfurization process and the increasing demand. The existing price difference based on available public bunker prices between distillate (0.1 - 0.5 % Sulfur) and residual fuel (2.0 - 3.5% Sulfur) is about \$300 USD more per ton for distillate. Based on a preliminary report on Low Sulfur (1%) marine fuels the premium cost of the lower sulfur HFO could be as much as \$100 USD/metric ton (Ref. 36). The prices of marine fuels at two European Ports for July 2012 are summarized in Table 4 (Ref. 37).

Table 4 shows the lower sulfur fuels are more expensive than the heavy residual fuels. The distillate fuels (LSMGO and MDO) have price premiums well above the residual fuels.

Table 4. Marine Fuel Prices July 2012 in USD/Metric Ton (MT)

Grade/ Port	High Sulfur Heavy Fuel (IF 380)	Low Sulfur Heavy Fuel (LS 380) (1% S)	High Sulfur Heavy Fuel (IF 180)	Low Sulfur Heavy Fuel (LS 180) (1% S)	LSMGO (0.1 % S)	MDO
Copenhagen	\$597.50	\$658.50	\$630.00	\$683.50	\$907.50	\$865.50
Rotterdam	\$580.00	\$631.50	\$602.00	\$653.00	\$865.00	-----

B. Characteristics - The cleaner fuels, especially if distillate is used, have different characteristics such as lower viscosity that can cause fuel system and engine operational problems. The engines can operate satisfactorily on the lower viscosity and lower sulfur fuels when the proper change over precautions are followed. When switching from a heavy fuel to distillate fuel there could be incompatibility problems that result in filter clogging, the proper lube oil Base Number must be maintained when operating on the high or low sulfur fuel and the viscosity must be maintained at the proper level to prevent fuel pump

damage. The fuel system modifications necessary for operation on both HFO and the low sulfur distillate add complexity to the already complex fuel system. There are also modifications required to the lube oil system so that the proper BN lube oil is used depending on the fuel sulfur level to avoid engine damage. MAN B&W has published a detailed manual titled "Operation on Low Sulfur Fuels" (Ref. 8) that explains the steps that should be taken for designing or modifying an existing HFO fuel oil system for operation on low sulfur fuels. When California enacted the low sulfur fuels requirement for ships in California Coastal Waters (CCW) ships experienced problems with engine stalling and loss of propulsion when shifting from residual to distillate fuel.

C. Future Availability - There is a concern that when the 0.1% ECA fuel sulfur limit takes effect in 2015 there could be a European shortage of MGO. Europe is currently in a net shortage of middle distillates and has to import them (Ref. 38). There could be a supply challenge in 2015.

7.3 Liquid Biofuels Characteristics:

A. Biodiesel (FAME) Advantages:

- **Fuel System and Engine Compatibility** – Many marine engine manufacturers have certified their engines for operation on Biodiesel or a blend of Biodiesel and diesel fuel. The Original Engine Manufacturer (OEM) should be consulted for the amount of biodiesel their engines can burn, i.e., B20, etc.
- **Lower SOx Emissions** - Neat Biodiesel contains almost no sulfur so SOx exhaust emissions are practically zero. Blending with regular diesel lowers the sulfur content proportionally.
- **Safety** - Biodiesel is as safe as diesel fuel. It has a higher flash point than diesel, is biodegradable and degrades quickly in water. The flash point of B100 is approximately 300 °F, compared to 120-170 °F for petroleum diesel.
- **Availability** – Biodiesel is commercially available at prices comparable to marine diesel fuel. For quality control it is produced to ASTM and EU Specifications. It has been classified as an advanced biofuel.

B. Biodiesel (FAME) Drawbacks:

- **Low Temperature Operation** – Biodiesel has a high cloud point compared with petroleum diesel that can result in filter clogging and poor fuel flow at low temperatures (32°F and lower). The feedstock used for the manufacture of the biodiesel has a strong influence on the cloud point. Additives can also be used to lower the cloud point.
- **Fuel System and Engine compatibility** – Biodiesel, especially in higher concentrations can dissolve certain non-metallic materials such as seals, rubber hoses, and gaskets. It can also interact with certain metallic materials such as copper and brass. For an existing ship the fuel system and engines may have to be modified by changing out susceptible parts with biodiesel compatible components for satisfactory operation.

- **Cleaning Effect** - Biodiesel especially in higher concentrations has a solvent/scrubbing action that cleans/removes deposits from the fuel system resulting in clogged fuel filters. The fuel system should be thoroughly cleaned, removing all deposits and residual moisture before using biodiesel or there will be inordinate high use of fuel filters.
- **Long Term Storage Stability** - Biodiesel can degrade over time forming contaminants of peroxides, acids, and other insolubles. For Biodiesel stored more than two months the fuels should be closely monitored and tested to see that it is within specification. An antioxidant can also be used (Ref. 39).

C. Algae Fuels Advantages:

- **Potential** – Algae can grow at amazing rates compared to farmland crops. These growth rates potentially translate to a very high biomass yield per hectare. However much research is still needed to fully utilize these potentials.
- **Fuel System and Engine Compatibility** – When Hydrotreated it is a drop in fuel when it comes to compatibility with the fuel system and engine components. Testing to date by the US Navy has shown no adverse effects from using a 50/50 blend of algae fuel and petroleum diesel fuel on engine and fuel system components.
- **Lower SOx Emissions** – Algae fuel contains almost no sulfur so the SOx exhaust emissions are practically zero. Blending with regular diesel lowers the sulfur content proportionally.
- **Safety** – Algae fuel is as safe as diesel fuel.
- **Performance** – Algae fuels have slightly lower heating values than petroleum diesel and lower aromatics. Blending with petroleum diesel negates these drawbacks so the blended fuel's performance compares favorably with petroleum diesel. Algae fuel is produced to a Hydrotreated Renewable Diesel (HRD) -76 specification and when blended with 50% petroleum diesel meets the requirements for petroleum diesel F-76. Figure 16 shows the comparison of the 50/50 blend with the petroleum F-76 fuel and the F-76 specification (Ref. 40).

Characteristic	MIL-DTL-16884L Requirements	Petroleum F-76 (typical)	50/50 Blend (actual)
Acid Number (mg KOH/g)	0.30 (max)	0.08	<0.05
Appearance	Clear & Bright	C & B	C & B
Ash (wt%)	0.005 (max)	<0.001	<0.001
Carbon Residue, (10% bottoms) (wt%)	0.20 (max)	0.07	0.09
Cloud Point (° C)	-1 (max)	-5	-11
Color	3 (max)	1	<2.5
Corrosion @ 100° C	1 (max)	1a	1a
Demulsification @ 25C (minutes)	10 (max)	3	2
Density @ 15° C (kg/m3)	800 – 876	845	806
Distillation (° C) - IBP	Record	180	189
10% Point	Record	218	205
50% Point	Record	282	263
90% Point	357 (max)	338	300
End Point	385 (max)	364	330
Residue + Loss (vol%)	3.0.(max)	2.0	1.8
Flash Point (° C)	60 (min)	65	65
Cetane Number	42 (min)	51	59
Hydrogen Content (wt%)	12.5 (min)	13.3	14.0
Particulate Contamination (mg/L)	10 (max)	2	2
Pour Point (° C)	-6 (max)	-11	-18
Storage Stab.(16) hrs	3.0 mg/100ml (max)	0.7	<0.1
Sulfur (wt%)	0.5 (max)	0.3	0.06
Trace Metals: Ca (ppm)	1.0 (max)	<0.1	<0.1
Trace Metals: Pb (ppm)	0.5 (max)	<0.1	<0.1
Trace Metals: Na+K (ppm)	1.0 (max)	<0.1	<0.1
Trace Metals: V (ppm)	0.5 (max)	<0.1	<0.1
Viscosity @ 40° C (mm2/sec)	1.7 - 4.3	3.3	2.3

Figure 16. Comparison of 50/50 Blend of Algae and F-76 Petroleum Fuel with Petroleum F-76.

D. Algae Fuel Drawbacks:

- **Availability** - Commercial availability is limited. The US Navy is the primary user and developer of the fuel for marine use. The Navy's plans are to reduce petroleum fuel use as much as possible in their fleet. There was a demonstration of the "Green Strike Force" in 2012 using a 50-50 Algae/Petroleum fuel blend and there are plans for the sailing of the green fleet by 2016.
- **Cost** - The current cost is prohibitive for general commercial use other than experimentally or for performance based demonstrations.
- **Performance** - The neat Algae fuel has lower heating value and aromatics than petroleum diesel but when blended with regular diesel fuel these drawbacks are negated.

E. Hydrogenation-Derived Renewable Diesel (HDRD) Advantages:

- **Fuel System and Engine Compatibility** – Hydrogenation-derived renewable diesel (HDRD) is produced by refining fats or vegetable oils in a process known as Fatty Acids to Hydrocarbon Hydrotreatment. Diesel produced using this process is called renewable diesel to differentiate it from biodiesel, which is a product of the transesterification of animal fats and vegetable oils. Renewable diesel and biodiesel use similar feedstocks but have different processing methods that create chemically different products.

HDRD has an identical chemical structure with petroleum-based diesel since it is free of ester compounds and when produced from waste animal fats has low carbon intensity and is referred to as "advanced" renewable diesel. It has a lower production cost because it uses existing hydro-treatment process equipment in a petroleum refinery. It has better low-temperature operability than biodiesel, thus it can be used in colder climates without gelling or clogging of fuel filters.

HDRD is similar to petroleum diesel fuel and is compatible with new and existing diesel engines and fuel systems. It is produced to meet current diesel fuel specification ASTM D 975.

- **Lower SO_x Emissions** - HDRD fuel contains almost no sulfur so the SO_x exhaust emissions are practically zero. Blending with regular diesel lowers the sulfur content proportionally.
- **Safety** – HDRD fuel meets the diesel fuel specification and is as safe as diesel fuel.

F. Hydrogenation-Derived Renewable Diesel (HDRD) Drawbacks:

- **Availability** – Current availability is limited. There are only few companies who have invested to produce hydrogenation-derived renewable diesel.

ConocoPhillips produces renewable diesel from vegetable oil and crude oil. Neste's plant in Porvoo, Finland, processes vegetable and animal fats into renewable diesel. Neste also has plants in Singapore and Rotterdam for the production of HDRD. Brazilian Petrobras uses co-processing of vegetable oils to make HDRD.

Cetane Energy LLC in Carlsbad, New Mexico, produces renewable diesel from vegetable oils and wastes. According to the company, its technology can work with a wide range of feedstocks including animal fat and algal oils. UK-based Renewable Diesel Europe is the exclusive agent in Europe for the standalone renewable diesel technology developed by Cetane Energy.

Other companies that have plans to produce or are producing renewable diesel fuel through hydrogenation include Nippon Oil in Japan, BP in Australia, Syntroleum and Tyson Foods in the U.S. (Dynamic Fuels), and UOP-Eni in Italy and the U.S. (Ref. 41).

7.4 Gaseous Fuels (Natural Gas (Compressed (CNG) or Liquefied (LNG))

Natural gas stored as LNG is a viable future marine fuel mainly for short sea shipping. Stored in the compressed form as CNG it is not considered viable because of long fueling times, extra space requirements for the fuel tanks, and the limited volume that can be carried that results in a limited range. For other than vessels on short voyages that have sufficient turnaround time for fueling, the CNG concept is not considered the best option when using natural gas for ships propulsion fuel.

A. Natural Gas Advantages

- **Availability** - With the new methods for extracting natural gas from shale formations using the fracking method the rate of development of new gas fields should assure an abundant supply for years. In the past couple of years, the growing global surplus of natural gas has become increasingly apparent. While much of the focus in the United States has been on the recovery of shale gas, overseas the discovery of enormous gas reserves in areas like offshore East Africa and the Caspian Sea has made it obvious that fears about scarcity were not well founded (Ref. 42). Availability is good in most parts of the world that ships sail to/from frequently.
- **Cost** - Natural gas is expected to be cost competitive with residual and distillate fuels through 2035. Currently it is 70% less than residual fuel and 85% less than distillate fuel and is expected by the EIA to hold this price advantage through 2035 (Ref. 43). The following chart (Figure 17) shows the price advantage that natural gas is projected to maintain over residual and distillate fuels through 2035.

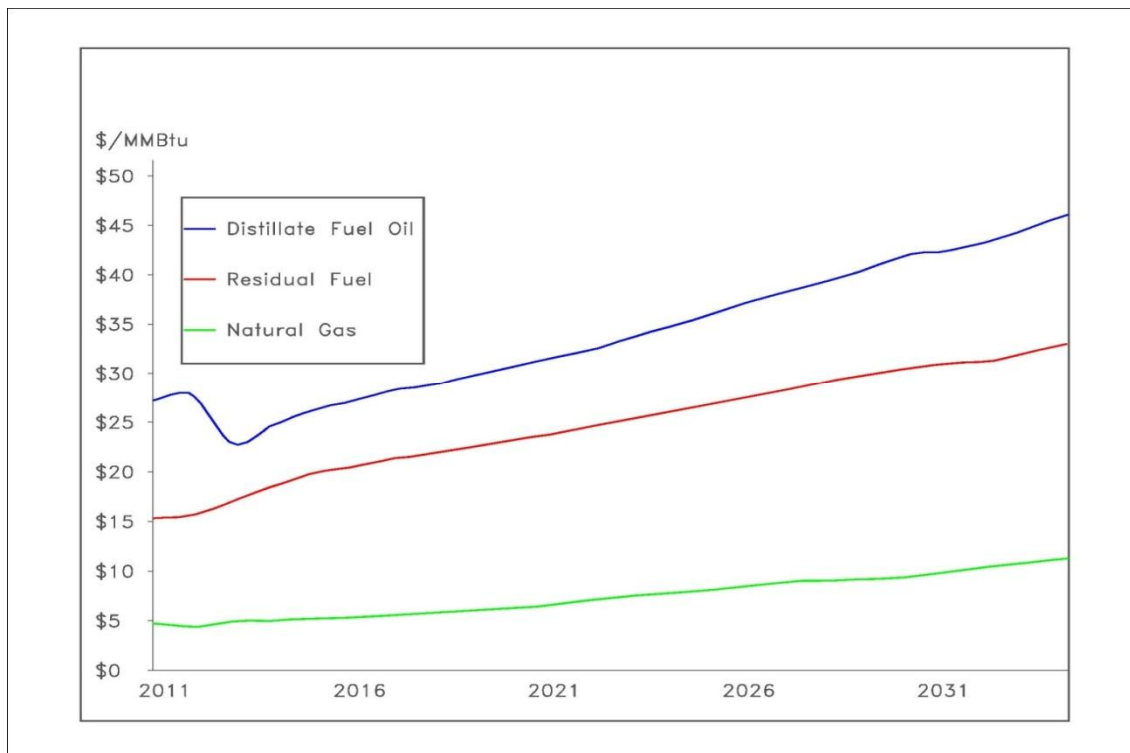

Figure 17. Projected Prices of Marine Fuels (Ref. 43)

- **Lower Exhaust Emissions** – The use of Natural Gas results in the following reductions of SO_x, NO_x, PM, and CO₂ from the Engine Exhaust Emissions. (Ref 44):
 - Carbon Emissions by approximately 25%
 - SO_x by almost 100%
 - NO_x by 85%
 - PM by 95%

It should be noted that while emissions of CO₂, SO_x, NO_x and PM are reduced significantly through the use of natural gas as a fuel there is a concern over methane slip. Methane slip will be included in the GHG picture, and thereby lead to high penalty on future CO₂ taxation etc. Methane slip will always be present with the known DF technologies (Otto cycle).

- **Ship Construction Rules** – Rules for the safe construction of ships using natural gas natural fuel have been developed and published by the Classification societies. There are Rules by Det Norske Veritas (DNV), Lloyd's Register (LR) and others.
- **Availability of Marine Gas Engines** - Gas burning or dual fuel marine engines in both slow and medium speed configurations are available from engine manufactures such as Wartsila, MAN B&W, and Rolls Royce (Bergen Engines). Wartsila developed a slow speed dual fuel engine in 1973 for marine use and followed with a high-pressure two stroke gas engine for marine use in 1986. Currently they offer a series of dual fuel medium speed marine engines. MAN B&W offers a slow speed marine gas engine and Rolls Royce has a medium speed marine gas engine that meets the Tier III NO_x limits that are effective in 2016. Mitsubishi Heavy Industries Ltd plans a combustion engine that efficiently burns high-pressure gas through direct injection. The engine will be marketed to customers after emissions levels and fuel economy are tested through a trial run that starts in late 2013 at Mitsubishi Heavy's Kobe shipyard. It is intended for liquefied-natural-gas carriers, large tankers and containerships (Ref. 45).
- **Experience with Natural Gas as Marine Fuel** - There is many years of experience with ships safely operating with LNG as the primary fuel. Section 8.2 describes ships operating with natural gas as a fuel.

7.5 Natural Gas Drawbacks

- **Not compatible with existing Engines and Fuel Systems** - Natural gas is not compatible with existing liquid fuel systems and requires modification of existing engines and changes or additions to the existing shipboard fuel systems as well as other changes for safety reasons. Table 5 from a report prepared by MJ Bradley for the American Clean Skies Foundation (ACSF) (Ref. 46) shows the costs associated with converting three different size vessels to natural gas service.

Table 5. Costs Associated with Converting Marine Vessels to LNG Operation

Type	Size (tons)	Engines	Engine Cost	Fuel System Cost	TOTAL CONVERSION COST
Tug	150	2 x 1500 HP	\$1.2 million	\$6.0 million	\$7.2 million
Ferry	1000	2 x 3000 HP	\$1.8 million	\$9.0 million	\$10.8 million
Great Lakes Bulk Carrier	19000	2 x 5000 HP	\$4.0 million	\$20 million	\$24 million

In comparison the conversion of the ðBit Vikingö a 177 meter long chemical product tanker to run on LNG was estimated to cost about \$10 million USD. Up to 75% of the conversion cost was covered by the Norwegian NOx fund, which awarded \$7million USD towards the project (Ref. 47).

- **New Ship Construction Premium** ó The cost of building a new ship powered by natural gas has a premium over the construction cost of a conventional ship with fossil fuel. There is a cost increase for the gas engines and another for the gaseous fuel system and associated LNG storage tanks. A GL study in 2009 noted a 25% additional investment over that of the cost for constructing a typical new container ship (Ref. 48). According to a DNV report if a ship spends more than 30% of its operating time in an ECA, gas fueled engines can be justified (Ref. 43).
- **Increased Fuel Storage Space** . Increased fuel storage space is required to carry the necessary volume of gas for endurance similar to a ship using liquid fossil fuel. A given weight of natural gas stored as LNG takes up only about 40% of the volume of the same weight of natural gas stored as CNG at 3600 psi. LNG occupies much less space than Compressed Natural Gas CNG and is the preferred storage method. When stored as LNG the fuel takes up twice as much space as the liquid fossil fuel, and if stored as CNG it takes up to five times as much space (Ref. 46). Table 6 shows the volume of the on-board fuel storage requirements for three types of marine vessels.

Table 6. Fuel Usage and Storage Volumes for Three Types of Vessels

Vessel	Fuel Type	HP	Daily Fuel Use [gal]	Typical Minimum On-board Fuel Storage		Volume of On-board Fuel Storage		
				[days]	[gal]	Dist. or Residual [ft3]	LNG [ft3]	CNG [ft3]
Towing Tug	Distillate	3,000	1,417	14	20,000	2,674	4,830	12,178
100-car Ferry	Distillate	6,000	2,268	7	16,000	2,139	3,864	9,742
Great Lakes Ore Carrier	Residual	10,000	6,934	21	145,000	19,385	38,183	96,264

Figure 18 from Reference 46 shows the relative weights and volumes of the marine fuels.

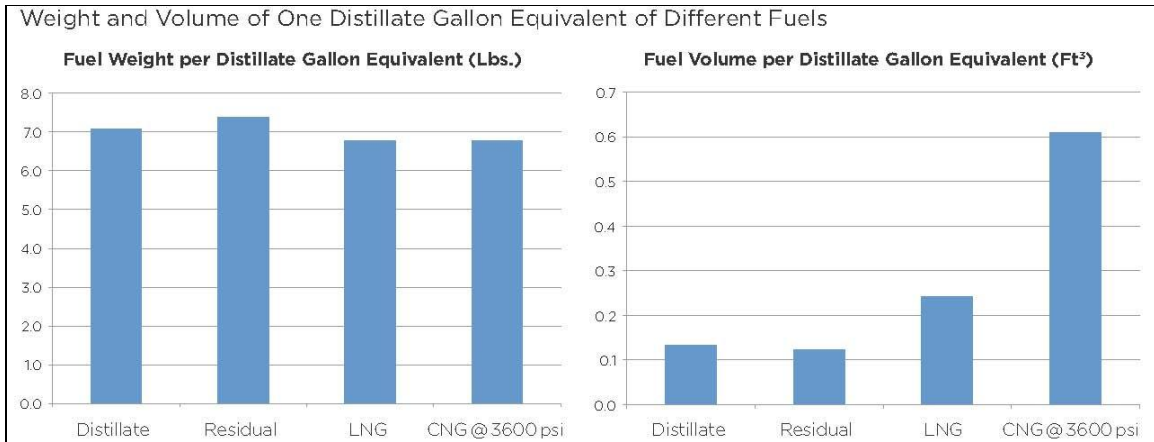

Figure 18. Weights and Volumes of Marine Fuels

- **Increased Fueling Time** - Stored as CNG it is not considered viable because of long fueling times, extra space requirements for the fuel tanks, and the limited volume that can be carried that results in a limited range. So for other than vessels on short voyages that have sufficient turnaround time for fueling the CNG concept is not considered the best option when using natural gas for the ships propulsion fuel.
- **Increased Safety Requirements** - The carriage of natural gas as a fuel entails additional safety requirements over fossil fuels and results in construction features that are reflected in the higher construction cost. (See paragraph on New Ship Construction Premium for the increased costs).
- **Limited Bunkering Infrastructure** - For LNG to become an attractive fuel for the majority of ships a global network of LNG bunkering terminals must be established or LNG fueled ships will be limited to coastal trades where there is an LNG bunkering network. The situation is sometimes described as a “chicken and egg” dilemma. Until the bunkering infrastructure is in place the ship owners may not commit to natural gas fueled ships and visa-versa. Currently LNG bunkering is more expensive and complicated than compared to fossil fuel and only available in limited places.

An Article by Germanischer Lloyd (GL) called LNG Supply Chain (Ref. 49), made the following observation:

- “At the end of 2011, no supply chain for LNG as ship fuel exists, with the exception of that serving Norwegian coastal waters. The primary reason for this is that LNG suppliers have yet to be convinced that this technology will take off. Moreover, LNG users have to be convinced that LNG will be made available at attractive price levels and the right locations.”
- "In principle, Europe is well prepared for this future as local LNG production is up and running in Norway. A number of large LNG import terminals already exist, with some of these having or planning an export facility, which is a necessary step towards small-scale LNG distribution. At present, however, large LNG terminals are not yet equipped for exporting smaller quantities of LNG”.

Since these statements were issued studies have been undertaken for LNG Bunkering Facilities within the European ECAs to have LNG supply capacity by 2015 and projects have been started to provide LNG bunkering capabilities at some ports. Oil and gas majors are showing an interest in developing an LNG marine fuel supply infrastructure. Shell has acquired Norwegian LNG producer and distributor Gasnor for \$74 Million with plans to target European Marine Customers. The purchase of Gasnor will give the oil major a foothold in the emergent market for LNG bunkering. Gasnor is an LNG supplier in Norway primarily by truck and is in the process of establishing LNG quayside bunkering at the German Port of Brunsbuttel (Ref. 50). A plan has been developed and land set aside for an LNG bunkering port in Rotterdam. A large Gas Access to Europe (GATE) LNG import terminal opened at the end of last year but this LNG is destined mostly for power plants. The principal companies involved want to build a smaller out bound terminal next to GATE so the LNG can be supplied as fuel for ships (Ref. 51). The Port of Rotterdam and the Port of Gothenburg plan to have infrastructure for LNG bunkering available once the lower marine fuel sulfur regulations come into effect in 2015 (Ref. 52).

A 1,305,000 LNG bunkering project being carried out by AGA AB in the Port of Stockholm, Sweden, is to go ahead with the help of a 261,000 contribution from the European Union's TEN-T program. The latter amount used for the conversion of an existing ferry by AGA AB to an LNG bunkering vessel for ship to ship bunkering.

AGA, which is supplying the fuel for the LNG-fueled ferry *öViking Graceö*, converted an existing vessel, the *Fjalir*, into a purpose-built LNG bunkering ship. It will provide 60 ó 70 Tons of LNG fuel on a daily basis to the *öViking Graceö*, which is initially being fueled from shore side, and later to other ships in the Port of Stockholm. The converted vessel was renamed the *öSeagasö*. The time spent fueling the *öViking Graceö* will be just under one hour and will be done ship to ship. Figure 19 shows *öSeagasö* alongside the *öViking Graceö*.



Figure 19. LNG Bunkering Ship “Seagas” alongside Viking Grace

The *Seagas* was named at a ceremony on March 20, 2013 and will be stationed at Loudden in Stockholm.

The bunkering vessel will be tested with 1,000 tonnes of LNG, corresponding to a reduction of 300 tonnes of CO₂ and 10 tonnes of SO₂ in terms of equivalent emissions from traditional shipping fuels. The test results will be measured in close collaboration with the Swedish Transport Agency and the Stockholm County Administrative Board, the main authority in charge of environmental permits.

The results will enable the potential of such a bunkering vessel to be evaluated as well as the need for future permits to be defined with regards to an increasing use of LNG as a fuel in the shipping industry.

The project will be managed by the Trans-European Transport Network Executive Agency and is set to be completed by December 2013 (Ref. 53).

Also planning for a European LNG Marine Fuel infrastructure is a 50/50 Joint Venture (JV) between Linde Group and bunker supplier Bomin. Linde Group has the contract to supply the LNG for the natural gas fueled ferry, *Viking Grace* and has partnered with Bomin to build a

European infrastructure for the supply of LNG fuel for ships. The JV will start its operations in the latter part of 2012 with headquarters in Hamburg. Linde will contribute its experience in cryogenics and its engineering know-how while Bomin will support the joint venture with its track record in maritime bunker fuel trading and operations. The new company will establish operations in a number of key ports throughout the ECAs in Northwest Europe. By 2015, approximately 70 vessels are expected to be operating on LNG in the Nordic region according to a study by the Danish Maritime Authority (Ref. 54).

Other ports are looking at the development of LNG bunkering facilities. Wartsila is working with Shell to develop the infrastructure for handling gas for marine bunkering. In the US they have a deal with Shell to supply the bunkering for the gas fueled ships in the US Gulf of Mexico such as the dual fueled OSVs by Harvey Gulf International Marine (Ref. 55).

In Asia Singapore has set up a joint industry project (JIP) to provide recommendations to the Singapore Government on enabling LNG bunkering in Singapore. The JIP will cover operational safety, alignment with industry expectations and best practices, and compliance with environmental and economic benefits to the ship-owners and the public (Ref. 56).

Lloyd's Register published a comprehensive 56 page study in August 2012 titled "LNG Fuelled Deep Sea Shipping - The outlook for LNG bunker and LNG-fuelled newbuild demand up to 2025". The study was started in April 2011. The object was to understand how a global LNG bunkering infrastructure might develop and to assess the likelihood of LNG being widely adopted as a fuel for deep sea shipping. In this study they:

- Identified strategic ports and locations worldwide for possible LNG bunkering infrastructure facilities, and gathered the opinions of bunkering ports on their likely provision of future LNG bunkering facilities.
- Assessed the likely scale of demand for LNG-fueled new construction and LNG as a fuel for deep sea shipping up to 2025, using a proprietary interactive demand model.

The results of the demand model, which is based on three possible future scenarios for LNG pricing and implementation of global sulfur limits, show that competitive pricing of LNG could see the fuel adopted widely for deep sea shipping.

The model showed there is a fine balance of influencing factors, such as fuel price differentials and the timing of global sulfur limit enforcement that will influence the marine industry's decisions about future fuels.

From a survey of shipowners on deep sea trades and bunkering ports they determined:

Deep Sea Trade:

- Low-sulfur fuel oil is a short-term option for compliance with SOx emission regulations.
- Abatement technologies are a medium term option.
- LNG-fuelled engines are a viable option in the medium and long term, particularly for ships on liner trades.

Bunkering Ports:

- LNG bunkering is expected for short sea shipping in ECAs.
- LNG bunkering may eventually cascade into deep sea trade facilitated by regulations.
- LNG bunker demand is highly dependent on LNG pricing and its comparable price difference with competing fuels, for example HFO and marine gas oil (MGO).

Using the LNG bunker demand model, three scenarios were examined based on assumptions of:

- Wider implementation of ECAs
- The implementation date of strict global sulfur fuel limits.
- The propensity of shipowners to adopt LNG as a fuel for newbuilds.
- Bunker fuel oil and LNG bunker price forecasts.

The details of the three forecast scenarios for LNG-fueled newbuilds and LNG bunker demand and the results of the demand model are listed below.

A Base case scenario that used current ECAs and a 0.5% global bunker fuel sulfur limit implemented from 2020 showed:

- 653 LNG-fueled newbuilds forecasted for the period up to 2025 (4.2% of global deliveries from 2012 to 2025).
- Cumulative LNG bunker demand is expected to reach 24 million tonnes (MnT) by 2025 for deep sea trades (1.5% of global LNG production and 3.2% of global HFO bunker consumption).

A High case scenario that used a 25% decrease on the forecast LNG bunker prices used in the base case model and a 25% increase in propensity compared to base case scenario for new builds to convert to LNG-fueled designs from 2020-2025:

- 1,963 LNG-fueled newbuilds forecasted for the period up to 2025 (12.6% of global deliveries from 2012 to 2025).
- Cumulative LNG bunker demand is expected to reach 66 MnT by 2025 for deep sea trades (4.2% of global LNG production and 8.0% of global HFO bunker consumption).

A Low case scenario that used a 25% increase in forecast LNG bunker prices used in the base case model and implementation of global sulfur limits shifting to 2023. Sensitivity testing indicated that shifting implementation to 2025 for the low case would generate a zero demand for LNG-fueled newbuilds:

- 13 LNG-fueled newbuilds forecasted for the period up to 2025 (0.1% of global deliveries from 2012 to 2025).

- Cumulative LNG bunker demand is expected to reach 0.7 Mnt by 2025 for deep sea trades (0.001% of global LNG production and 0.002% of global HFO bunker consumption).

Lloyd's Register also noted that operating on low-sulfur distillate fuels is a relatively easy way to comply with fuel oil sulfur limits but expressed concern that if the world fleet of commercial ships converts to using distillate fuel by 2020, the current production of distillate fuel oil would **not** meet marine bunker fuel demand.

According to a recent report (Meech, 2011), Outlook for Marine Bunkers and Fuel Oil to 2030, the refinery industry would need to produce an additional 4 million barrels per day of distillates in order to meet demand for bunker fuel oils for shipping on implementation of the 2020 IMO global sulfur limits.

Lloyd's Register observed from their port survey that where an LNG import terminal exists, or is being developed nearby, most ports see the importing terminal as a key driver of providing LNG in small parcels for bunkering operations.

Lloyd's Register concludes LNG as a fuel is one option for deep sea shipping to comply with future emission regulations.

Using surveys of shipowners on deep sea trades and bunkering ports, and modeling of LNG fueled newbuild and bunker demand, they arrived at the following conclusions:

1. LNG-fuelled engines are a viable option for deep sea trades in the medium term (5-10 years) and long term (10+ years), particularly for ships on liner trades. This conclusion can be drawn from both the shipowner survey as well as the bunkering port survey.
2. Considering the base case scenario model, with what we know today about the factors affecting adoption of LNG, 653 newbuilds are expected to adopt LNG-fueled engines by 2025 on deep sea routes. This represents 4.2% of global newbuilds forecast to be delivered during the period 2012-2025.
3. The high case scenario model output was much more favorable towards LNG-fueled newbuilds when the forecast price of LNG bunker fuel was reduced by 25%. On the other hand, the low case scenario model ó with a higher forecast price of LNG bunker fuel and a later implementation date of global sulfur limits ó generated demand for just 13 LNG-fueled newbuilds for deep sea shipping up to 2025.
4. LNG bunker demand is highly dependent on LNG pricing and its comparable price difference with competing fuels, e.g., current and future alternative fuels. This conclusion can be drawn from the bunkering port survey and is confirmed from outputs of the LNG demand model for LNG-fueled newbuilds and LNG bunkering in the low case scenario.

Lloyd's Register will continue monitoring global commercial developments of LNG as a fuel, and provide annual updates of the forecasts of LNG fueled newbuilds and LNG bunker demand. In addition, they will carry out ongoing validation and sensitivity studies for the model, updating it annually and involving industry stakeholders including gas suppliers, engine makers, shipowners and shipyards (Ref. 57).

A comprehensive North European LNG infrastructure study was released in March, 2012 in Denmark (Ref. 26). Belgium, Denmark, Finland, Norway, and Sweden participated in the study.

The infrastructure for the use of LNG for ships in Denmark was investigated by Litehauz (Ref. 58) in 2010. This region is dominated by short sea shipping around the Baltic Sea.

The general conclusion of this study is that if the investments in ports and vessels are limited to the most fuel consuming ports and vessels, fuel cost savings will cover the investments. This does not include ocean going ships, only ships that port regularly in ports within the ECA area.

The key barriers for introduction of LNG identified in the Denmark study are:

Barriers	Possible actions
<u>Technical:</u> More demanding footprint on board the vessel that takes up commercial space	New design and technical development of tanks and reconsideration of safety measures
<u>Supply:</u> For short sea shipping filling stations in key ports are lacking	Provide funds for pilot projects, technology developments etc.
<u>Filling station/bunkering</u>	Develop options for mobile tanks to be trucked on board and installed
<u>Regulation:</u> Safety regulation for ship to ship transfer. Safety regulation for bunkering while passengers are on board	Efforts to support the development of revised rules. Develop safety measure to allow bunkering while passengers are on board
<u>Political-administrative:</u> No reward for natural gas conversion in public tenders	Build in criteria in tenders to incentivise investments
<u>Concession periods too short for capital investments</u>	Prolong concession periods, where possible

Barriers to the introduction of LNG do not appear to be technical but associated with supply chain issues and obvious economic issues. Several manufacturers have addressed the technical barriers regarding engines/turbines and most of the prominent remaining issues appear to be associated with the filling stations and the storage on board.

To summarize, the following are the key findings related to the use of LNG for ships in Denmark:

- Propulsion technology in ships is mature and proven
- Distribution network is not yet developed for use in ships
- Safety concerns are demanding but manageable
- Can enter existing bunkering value chain

An immediate focus on the ferry sector in Denmark will reap benefits in a relatively short time. For the short sea shipping sector a way to promote the conversion to LNG is to support the development of storage and bunkering facilities in main ports. Given the general expectations in

the shipping community LNG will presumably be the de facto choice at least for the next 5-10 years and the demand for facilities and bunkers will be for LNG.

It should be noted that LNG terminals in Figure 20 are mostly relatively small units that cannot supply an ocean going container vessel or similar but mainly serve small supply boats and ferries. LNG bunkering vessels will be needed for ocean going vessels that are restricted by draft or size.



Figure 20. Existing and Planned Production Plants and LNG Terminals in the SECA (Ref. 26)

In other LNG bunkering news Shell Oil is moving to bring LNG fuel one step closer for its marine and heavy-duty on-road customers in North America by taking a final investment decision on two small-scale liquefaction units. These two units will form the basis of two new LNG transport corridors in the Great Lakes and Gulf Coast regions.

In the Gulf Coast Corridor, Shell plans to install a small-scale liquefaction unit (0.25 million tons per annum) at its Shell Geismar Chemicals facility in Geismar, Louisiana, United States. Once operational, this unit will supply LNG along the Mississippi River, the Intra-Coastal Waterway

and to the offshore Gulf of Mexico and the onshore oil and gas exploration areas of Texas and Louisiana.

To service oil and gas and other industrial customers in Texas and Louisiana, Shell is expanding its existing relationship with fuels and lubricants re-seller Martin Energy Services whose publicly traded affiliate, Martin Midstream Partners L.P. will provide terminals, storage, transportation and distribution of LNG.

Shell has a memorandum of understanding with Edison Chouest Offshore companies (ECO) to supply LNG fuel to marine vessels that operate in the Gulf of Mexico and to provide what is anticipated to be the first LNG barging and bunkering operation in North America at Port Fourchon, Louisiana. LNG transport barges will move the fuel from the Geismar production site to Port Fourchon where it will be bunkered into customer vessels.

In the Great Lakes Corridor, Shell plans to install a small-scale liquefaction unit (0.25 million tons per annum) at its Shell Sarnia Manufacturing Centre in Sarnia, Ontario, Canada. Once operational, this project will supply LNG fuel to all five Great Lakes, their bordering U.S. states and Canadian provinces and the St. Lawrence Seaway. The Interlake Steamship Company is expected to be the first marine customer in this region, as it begins the conversion of its vessels. Pending final regulatory permitting, these two new liquefaction units are expected to begin operations and production in about three years (Ref. 59).

Using small-scale liquefaction technology, Waller Marine plans to install nominal 500,000 gallon per day LNG trains in phases as the market and demand for marine LNG fuels expands. The first trains are planned for the Waller Point LNG terminal in Cameron Parish, LA and additional trains are planned for a second terminal that it is developing through its subsidiary Waller Energy Partners, LLC, at a site to be secured on the Mississippi River in the first quarter of 2013.

To enable the supply and distribution of LNG to and from small scale LNG terminals and for bunkering LNG as a marine fuel, Waller has also conceived and designed a series of small LNG vessels ranging from its 2,000 to 10,000 cubic meter capacity river transport and bunker barges and its 10,000 to 30,000 cubic meter coastwise ATB LNG vessels. Figure 21 shows Waller Marine's 30,000 cubic meter ATB LNG RV bunker barge. Waller has approval in principal from ABS.

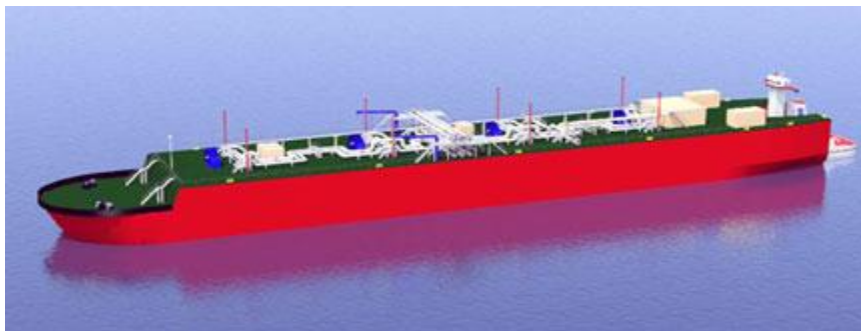

Figure 21. LNG Bunkering Barge

Waller Marine says with strategically located LNG supply facilities, a distribution by Waller barges to small-scale LNG storage terminals combined with ship fueling with Waller LNG bunker barges at anchorages, ports and terminals throughout the U.S., vessel owners will have access to competitively priced LNG. Waller anticipates that substantial savings can be achieved by vessel owners using LNG fuels with payback for conversion costs being as short as six months. Waller has also initiated a vessel conversion strategy and is working with partners on providing funding for the conversion of ships to be fueled by LNG. Working with engine manufacturers and equipment suppliers, Waller is engineering shipboard LNG fuel storage and supply systems for vessels having a range of horsepower. They are also developing pre-manufactured systems to reduce or eliminate downtime during conversion.

7.6 Future Marine Fuel Use.

Table 7 shows a best estimate distribution and mix of marine fuel consumption in 2020. Fossil fuels are considered to remain the dominate fuel with LNG showing a large percentage usage by smaller vessels on fixed routes operating in SECAs and ECAs.

Table 7. 2020 Marine Fuel Mix (Mton/year)

Vessel types	Small vessels, ferries etc.	Cargo ships with sulfur removal	Cargo ships without sulfur removal	Total
No. of vessels	55.000	30.000	20.000	105.000
HFO [Mton/yr]	-	204	-	204
LSFO [Mton/yr]	-	-	110	110
MGO/MDO [Mton/yr]	44	-	25	69
LNG [Mton/yr]	15	-	-	15
Biofuels etc. [Mton/yr]	1	-	1	2
Total fuel [Mton/yr]	60	204	136	400
Market per cent	15%	51%	34%	100%

Lloyd's Register predicts the following use of LNG using their base, high and low case scenarios by 2025 (Ref. 57).

Scenario	Newbuilds using LNG as fuel for deep sea trades 2012	Cumulative LNG Consumption 2012-25 for deep sea trades (MnT)
Base Case	653	24
High Case	1,963	66
Low Case	13	0.7

8. Vessels Using Alternative Fuels

The following paragraphs discuss the types of vessels currently or under contract or have been modified and the marine fuels they are using for compliance with the low sulfur fuel and NO_x emission requirements.

8.1 Vessels Using ULSD and LSRF

Currently vessels using residual fuels are switching to a LSRF, a distillate fuel or a blend of distillate and residual to meet the ECA fuel sulfur limits and fuel sulfur limits in low fuel sulfur zones such as California's Coastal Waters (CCW) fuel sulfur requirements within 24 nautical miles (nm) of the California coast and the European Union (EU) Ports Directive 2005/33/EC that requires 0.1% maximum sulfur limit on fuels used at berth in EU ports (Ref. 60). The European Union port directive for low sulfur fuel was effective 1 January 2010. In the United States and Canada for 2012 the distillate marine fuel is ULSD so the majority of vessels fueling with marine diesel in the US are using the ULSD fuel that is well within the ECA sulfur limits. About 70% of US shipping relies on distillate fuel oil and the remaining 30% relies on residual fuel oil. By contrast, over 90% of international shipping is fueled by residual fuel oil (Ref. 46). The use of low sulfur distillates or low sulfur residual fuels is by far the most prevalent at this time. The use of scrubbers for SO_x removal is not widespread at this time.

The future availability of these low sulfur bunkers is of concern to the shipping industry especially the 0.1% Sulfur in the ECAs in 2015 and the 0.5% Sulfur that must be used globally. The International Chamber of Shipping (ICS) has called on the IMO to expedite a study on the world wide availability of low sulfur bunkers and if availability issues could impact the cost of these fuels making them prohibitively expensive (Ref. 61).

8.2 Vessels Using Natural Gas

Vessels currently using natural gas as a fuel are mostly in the small to medium size range with larger ships being built or converted for operation on LNG fuel. The only large ships currently using LNG as a fuel on international voyages are LNG carriers. The following paragraphs describe the distribution of LNG fueled vessels and what the future looks like for new LNG fueled ship construction.

Small-Medium Size – The majority of ships operating on natural gas today are small to medium size consisting of offshore supply vessels (OSVs), car and passenger ferries, patrol craft and tugs. In the spring of 2011 there were 22 vessels operating on LNG fuel and all except one was operating in Norway. This number has increased to 37 according to DNV in the March 2013 Marine Log report titled "Who Has Gas and Who Wants It?" and they expect this number to be 63 by 2015. These numbers do not include LNG Carriers.

Eighteen more (18) natural gas vessels are to be delivered in 2013 with many more planned. In addition to the ship types mentioned RO-RO ships are included among the new builds (Ref. 62). Delivered this year (2013) is the 214 meter long LNG fueled passenger vessel "Viking Grace" for Viking Lines with a capacity of 2800 passengers (Ref. 63). The 57,000-gt M/S Viking Grace entered service between Turku, Finland to Åland Islands, Stockholm, Sweden, on January 15. The four Wärtsilä 8L50DF dual-fuel engines and associated technology enables the Viking Grace to sail without restrictions in Sulfur Emission Control Areas (SECAs) and Nitrogen Emission Control Areas (NECAs) (Ref. 64).

Norwegian shipping company Fjord Line's two new 170 meter international cruise ferries will be powered by LNG. When the Fjordø line MS Stavangerfjord is put in operation in April this year (2013), it will be the first and largest cruise ferry in the world to sail with a "single LNG engine," Fjord Line chose Rolls-Royce as the supplier of the LNG engines. Emissions of the Rolls-Royce engines are below the limit values of IMO Tier III. The Rolls-Royce engines supplied for each ferry were four, 12-cylinder LNG engines of type B35:40V12PG with an output rating of 5,600 kW@750 rpm. The ferries have 306 cabins and space for more than 1500 passengers and 600 cars (Ref. 65).

Two recently ordered Norwegian fish feed transporters are to be LNG-fueled. They will have an advanced LNG-gas-electric propulsion system. The main particulars are 69.90 m LOA, with a beam of 17.20 m, and depth of 7.90 m from upper deck. Delivery of the vessels is planned for June and September 2014 (Ref. 66).

In addition to the European LNG fueled vessels mentioned Harvey Gulf International Marine of New Orleans, LA is building five 302 foot STX-Marine designed dual-fuel OSVs at Trinity Offshore Yards, Gulfport, MS in the United States (Ref. 67 and Ref. 68). The OSVs will use Wärtsilä 6 Cylinder 34 DF dual-fuel engines and the Wärtsilä LNGPac system technology. Shell oil has chartered three of the Harvey Gulf OSVs for use in support of Shell's operations in the US Gulf of Mexico. Also planned for North American service is a 130 meter long Canadian ferry that can use either natural gas or marine diesel fuel that has been ordered by Canada's Societe des traversiers du Quebec (STQ). It will have a capacity of 800 passengers and 180 cars. The diesel electric propulsion plant will have four diesel powered generators (Ref. 69). The ship is being built by Fincantieri Cantieri Navali Italiani in Italy and will be used on routes crossing the St. Lawrence River. The ferry vessel is scheduled for delivery by the end of 2014 (Ref. 68). Wärtsilä has been awarded the contract for the gas powered propulsion machinery. The Wärtsilä 34 dual-fuel generating sets will provide the main power generation and can be switched to marine diesel oil (MDO) for fuel redundancy if LNG is not available. Wärtsilä will also supply its LNGPac system consisting of onboard fuel storage tanks, LNG bunkering, and handling equipment. Wärtsilä will also provide the safety control and automation systems (Ref. 70).

For South American service Australian shipbuilder Incat Tasmania Pty Ltd launched the world's first high speed passenger RO/RO ship to operate on LNG. Sea trials are expected to take place January 2013. The 99 m LNG ship was built for South American company Buquebus for operation on its River Plate service between Buenos Aires, Argentina and Montevideo in Uruguay. It has a capacity for over 1000 passengers and 153 cars, with a projected lightship speed of 53 knots, and an operating speed of 50 knots. The vessel will be the first installation of LNG powered dual fuel engines in an Incat high speed ferry, and the first high speed craft built under the HSC code to be powered by Gas Turbines using LNG as the primary fuel and marine distillate for standby and ancillary use (Ref. 71).

In China a contract was signed in July 2012 for two dual fueled 6,500 HP tugs. The vessels will each be powered by two 6-cylinder Wärtsilä 34DF in line dual-fuel engines. The first of the tugs is expected to be delivered in June 2013 (Ref. 72).

Table 8 lists new LNG Fueled vessels ordered through 2015 (Ref. 73).

Table 8. Current Order Book for New LNG Fueled Vessels (2012-2015)

(Does not Include LNG Carriers, Inland Waterway Vessels and Conversions)

Delivery Year (Number of Vessels)	Vessel Type	Owner	Classification Society
Delivery 2012 (4)	Platform Supply	REM	DNV
	Car/Passenger Ferry	Toøghatten Nord	DNV
	Car/Passenger Ferry	Toøghatten Nord	DNV
	Harbor Vessel	Incheon Port Authority	DNV
Delivery 2013 (18)	High-Speed RoPax	Buquebus	DNV
	Ro-Ro	Sea-Cargo	DNV
	Ro-Ro	Sea-Cargo	DNV
	RoPax	Fjordline	DNV
	RoPax	Fjordline	DNV
	General Cargo	Eidsvaag	DNV
	Car/Passenger Ferry	Norled	DNV
	Car/Passenger Ferry	Norled	DNV
	Ro-Ro	Nordlines	DNV
	Ro-Ro	Nordlines	DNV
	RoPax	Viking Line	LR
	Tug	Bukser and Berging	DNV
	Platform Supply	Harvey Gulf Intø	ABS
	Platform Supply	Harvey Gulf Intø	ABS
	Patrol	Finnish Border Gd.	GL
	Car/Passenger Ferry	STQ	LR
Tug	CNOOC	CCS	
Tug	CNOOC	CCS	
Delivery 2014 (9)	Car/Passenger Ferry	STQ	LR
	Car/Passenger Ferry	STQ	LR
	Tug	Bukser and Berging	DNV
	Platform Supply	Harvey Gulf Intø	ABS
	Platform Supply	Harvey Gulf Intø	ABS
	Gas Carrier	SABIC	BV
	Gas Carrier	SABIC	BV
	Platform Supply	Remey Shipping	DNV
	Platform Supply	Siem Offshore	DNV
Delivery 2015 (3)	Platform Supply	Harvey Gulf Intø	ABS
	Containership	TOTE	ABS
	Containership	TOTE	ABS
Notes:	(1) Harvey Gulf International Marine has options for up to five more dual fuel PSVs.		
	(2) TOTE holds options for three more container ships.		

A number of conversions to LNG are planned or have been completed. Some recent and planned vessel conversions to LNG are discussed in the following paragraphs.

The Bit Viking (Figure 22) a 177 meter long, chemical product tanker originally delivered in September 2007 was converted to LNG from HFO and redelivered to her owner in October 2011. She currently is operating along the Norwegian Coast. Two LNG storage tanks with a combined capacity of 1,000 cubic meters located on the ship's main deck give Bit Viking an endurance of 12 days steaming at 80% load (Ref. 74).



Figure 22. “Bit Viking” with LNG Fuel Tanks on the Main Deck

Washington State Ferries (WSF) has sent out a Request for Proposal (RFP) to convert six (6) of their Issaquah Ferries to burn LNG. The 328 foot long ferries were built in 1980 to carry 1,200 passengers and 100 cars. Five were modified for 130 cars in the 1990s. The Washington State Ferry system burns more than 17 million gallons of ultra-low sulfur diesel each year considers this their fastest growing operating expense. They believe LNG has the potential to significantly reduce emissions and the cost of fuel (Ref. 68).

The WSF retrofit plan estimates a fuel savings of \$195.5 million from the first conversion in 2015 to the retirement of the last converted ferry in 2042. The use of LNG would also reduce emissions. The ferries would be retrofitted with new gas only or dual fuel engines and two 100 cubic meter LNG tanks located on the upper deck not used by passengers (Ref. 75).

To ensure that the safety, security and operational challenges of such a move is handled in a responsible manner, WSF has partnered with DNV, which has extensive experience with LNG-fueled vessels and the infrastructure they require (Ref. 68).

WSF has received conceptual approval from the U.S. Coast Guard to retrofit the propulsion system with new engines on the six Issaquah Class ferries to use LNG as a source of fuel. These vessels would be fueled by trucking in LNG from sources in British Columbia or the Pacific Northwest. Figure 23 shows the LNG tanks on the top deck of the Issaquah Class ferry (Ref. 68).



Figure 23. LNG tanks on top deck of WSF Issaquah Class ferry

New York City plans to convert one of the diesel oil-fueled Staten Island 'Austen-class' ferries to use LNG for fuel. If successful, the conversion could save the city nearly half the boat's fueling cost annually. The ferry will be converted to LNG during a routine dry docking in 2013.

The Staten Island Ferry received a \$2,340,000 federal grant, and the city contributed additional money to reach \$3 million for the conversion (Ref. 76).

Totem Ocean Trailer Express (TOTE) of Tacoma, Washington plans to convert two of their existing ships to LNG. TOTE has finalized a contract with General Dynamics NASSCO to design the conversion of two of their ORCA class Roll-On/Roll-Off ships to burn LNG. In August 2012 TOTE received a permit from the US Coast Guard providing a conditional waiver from the North American ECA fuel sulfur requirements while it converts the vessels to LNG (Ref. 77). The engineering, design, and installation of the engine kits and construction of the LNG plant could cost \$84 Million for the two ships and take up to five years. The conversion will take place while the ships are in service. The 839 foot long ships operate between Tacoma, WA and Anchorage, AK serving the Alaskan market. The shore side support infrastructure being built to support the ships will help other transportation industries in Puget Sound to convert to LNG (Ref. 78). The company has contracted with General Dynamics NASSCO for the conversion design (Ref. 79).

Large Ships - The majority of large ships using LNG fuel for their engines are ships carrying natural gas in the liquefied state as LNG cargo and that use the boil off from their cargo as fuel for their propulsion and auxiliary engines. There were 359 LNG ships engaged in the deep-sea movement of LNG at the end of 2011 (Ref. 80).

Designs for large ships using LNG fuel have been developed and a contract for two new LNG powered container ships has been announced. International classification society Bureau Veritas (BV) has given approval in principle for the basic design of a 14,000 teu containership to be powered by LNG. The design was developed in a joint industry project between Korea's Daewoo Shipbuilding & Marine Engineering (DSME), liner major CMA-CGM and BV. A feature of this design is that the vessel can also run on HFO if required, increasing flexibility in the period before LNG bunkering is widely available. The basic design is for a 365.5 meter length over all (LOA) vessel with a design draft of 14 m and a design speed of 24 knots. The main engine would be rated at a Maximum Continuous Rating (MCR) of 72,285 kW and the vessel would have a range of 25,000 miles fully bunkered. Compared to the same ship with a conventional fuel power plant there will be extra capital cost for the engine and for the LNG tank and gas handling system, and there is a loss of cargo space equivalent to 438 teu to make room for the gas tank and equipment. But the extra capital cost and the loss of earnings on a theoretical full ship are more than offset by the fuel economies and lower emissions of this design (Ref. 81).

DSME also participated in a joint research project with A.P. Moller Maersk for the design of a 7,000 TEU container ship burning LNG as a fuel for both propulsion and power generation. The American Bureau of Shipping (ABS) provided approval in principal in May 2011.

Also recently announced is the "Green Dolphin" design for a 180 meter LOA Bulk Carrier that has as one of its variants the use of LNG as fuel. The engines can be retrofitted to be dual fuel (Ref. 82).

TOTE has contracted for the construction of two LNG powered containerships to be MAN powered and NASCCO built. They will be state of the art 764 foot long, 3100 TEU container ships for the Puerto Rican trade with options for three more for domestic service. The ships will be built by General Dynamics NASSCO San Diego, CA. Construction of the first ship is scheduled to begin the first quarter of 2014 with delivery in the fourth quarter of 2015. The second ship is scheduled for delivery in the first quarter of 2016. They will be used in service between Jacksonville, FL and San Juan, PR. The ships will be designed by Daewoo Ship Engineering Company (DSEC) and will include DSME's patented LNG fuel system and a MAN 8L70ME-GI dual fuel slow speed diesel engine. The double walled type-C LNG fuel tanks will be located behind the ship's accommodation block above deck for safety, cargo loading, and space utilization. See Figure 24 for a conceptual illustration of the new TOTE Container ship showing the stern location of the LNG fuel tanks (Ref. 83).



Figure 24. Concept Illustration of TOTE Container Ship

It is estimated that between 2012 and 2020; 15 ó 20 % of the new buildings will have the capacity for burning LNG as a propulsion fuel. This equates to approximately 1,000 ships (Ref. 43).

8.3 Vessels Using Liquid Biofuels

The use of liquid biofuels is an attractive alternative for marine owners and operators since their use can usually mean lower sulfur emissions and ship conversions are manageable and not as expensive as modifying an existing ship for LNG. However, the cost, limited availability, and non-compatibility issues of some biofuels such as biodiesel (FAME) may limit their use in the near future. There are exceptions and those marine users attempting the large scale use of liquid biofuels are discussed in the following paragraphs.

One exception to this is the biofuel and petroleum blend that the US Navy has developed for use in their fleet. The fuel is produced to the Navy developed Hydrotreated Renewable Diesel-76 (HRD-76) Specification and consists of 50% HRD-76 fuel and F-76 petroleum diesel. The fuel is truly a drop in fuel and does not require any modifications to existing engines or the ships fuel systems.

The Navy awarded a contract for 450,000 gallons of the biofuel; the contract involves supplying the Navy with 100,000 gallons of jet fuel (Hydro-treated Renewable JP- 5 or HRJ-5) and 350,000 gallons of marine distillate fuel HRD-76. The fuel will be used as part of the Navy's efforts to develop a "Green Strike Group" composed of vessels and ships powered by biofuel (Ref. 84).

The fuel will be manufactured at Dynamic Fuel's Geismar, Louisiana, renewable fuels plant using U.S. sourced yellow grease (used cooking oil) as well as Solazyme's tailored algae oil as feedstocks. The Dynamic Fuels plant, which has been in operation for more than a year, is designed to convert non-food feedstocks such as algae oil, animal fats, and greases into renewable fuels (Ref. 84).

As the availability of biofuels increases especially the second generation biodiesels there will be the opportunity to supply the marine market with biofuels that can substitute for marine distillate fuels.

Stena Line is experimenting with liquid biofuel on a large scale and plans to use methanol to meet emission standards for Europe's SECAs coming into effect in 2015. They are working together with Wärtsilä and other project partners to apply for co-funding of the co-pilot project under the Trans-European Transport Network (TEN-T) scheme to convert the Stena "Germanica" ferry to run on methanol in 2014. Stena believes that its project fits neatly in line with the scheme's objective to invest in projects that will deliver and make a difference (Ref. 85).

Methanol can be produced as a biofuel and is sustainable since it can be made from cellulose and doesn't compete with food sources. It can also be synthesized from CO₂ and hydrogen.

Stena has launched and is conducting a test for using methanol with the first trial taking place on Gothenburg-Frederikshavn train ferry Stena Scanrail. Depending on the outcome, Stena plans to convert the "Stena Germanica" in the first half of 2014 (Ref. 86).

In the long term if the trials are promising, Stena has a vision to run the whole of its SECA fleet on methanol and it has an ambitious target of converting 25 vessels to methanol by 2018.

9. The Way Forward for Future Marine Fuels

As the shipping industry considers alternatives to HFO, part of the market will shift towards MGO, part towards LNG and some possibly to liquid biofuels. Marine vessels equipped with scrubbers will retain the advantage of using lower priced HFO. Shipping that takes place outside ECA areas might choose HFO or LSFO depending on future global regulations. Ships operating partly in ECA areas will probably choose MGO as compliance fuel. Heavy shipping within ECA areas however might require a complete shift to LNG.

Unlike the case for road transportation, fuels are not simply procured by the vessel owner according to engine manufacturer's specification. In fact the choice of fuel lies primarily with the Charterer (the shipping agent) who in principle rents the vessel from a ship owner. Depending on the engine type the charterer then has a choice of fuels. Typically high sulfur residual fuels or low sulfur distillates are among the choices. Depending on the abatement technologies installed by the ship owner and the requirements set by the authorities in the specific region of operation, the charterer then selects and acquires the fuel. (Ref. 35, Leif Holmberg, Technical Manager, Rederi AB Transatlantic).

Figure 25 shows the influents on the buying process of marine fuels for large freight vessels. The choice is basically on the charterer, who also has to select a vessel for each transport. The choice of fuel is then affected by many factors, such as emissions requirements on the selected route, the fuels availability and

price, and the abatement equipment installed on the ship. The contract duration will be influencing the owner's decision on whether to retrofit abatement equipment.

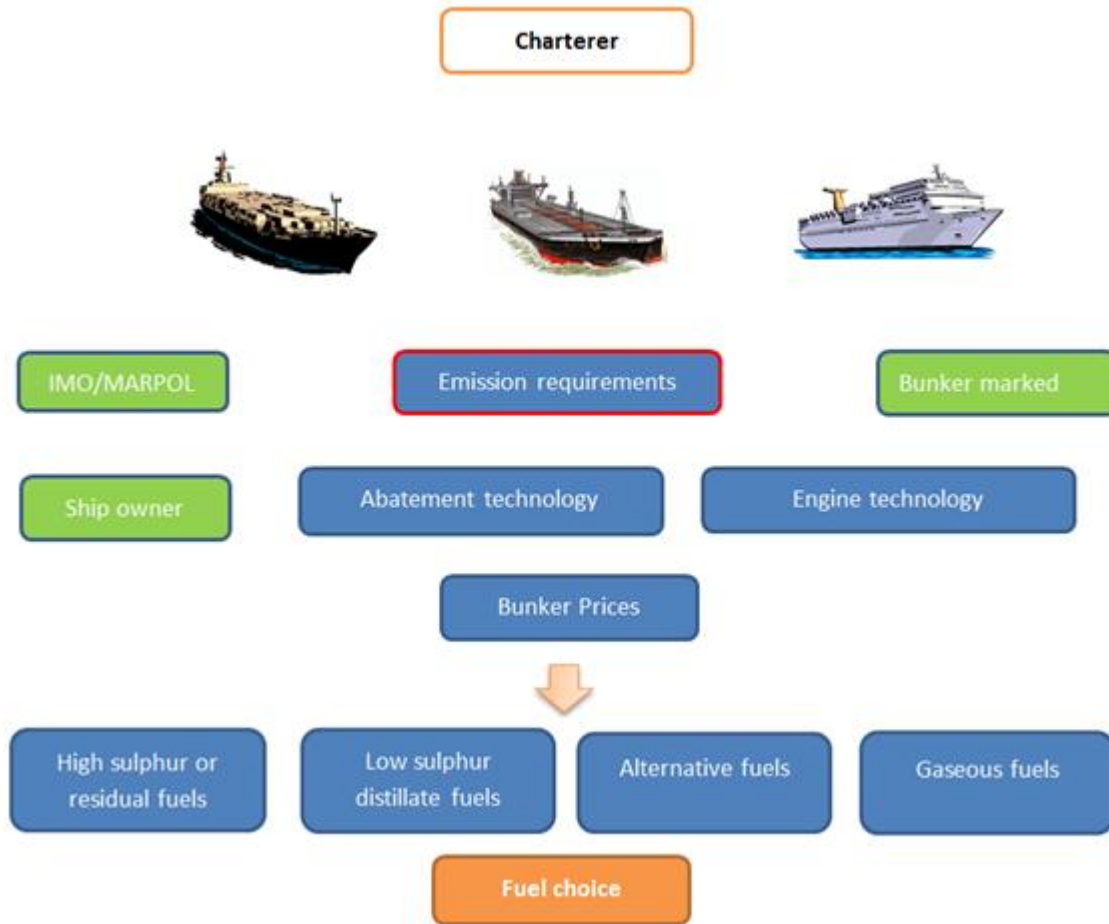

Figure 25. Fuel Selection Process is Responsibility of Charterer and is influenced by Many Factors

Figure 25 applies to large freight vessels. Other segments (groups of customers) are private boats, fishing boats, ferries etc. In terms of global fuel use however freight vessels are dominant. According to IMO international shipping consumes approximately 83% of global marine fuel use.

With reference to the organizational aspects it is important to notice that IMO is an organization of major importance. Therefore it is also essential to pinpoint the decision-making processes that underlie the birth of IMO requirements and how IMO is influenced by different partners.

IMO issues the MARPOL convention Annexes which contain the actual emission requirements. Current International marine emission requirements are discussed in Section 3.

Break even points (Figure 26) - When deciding on a strategy for complying with emission laws the all-important trade-off is the cost of low sulfur fuel vs. the cost of a scrubber system. Such a system cost is in the region of 3 million USD. Depending on the on-cost for low sulfur fuel the break-even point thus

lies in the region of 7-30 Megaton of fuel used within the amortization period (3-5 years). The pay back times were investigated by a Danish consortium called Green Ship of the Future (Ref. 87).

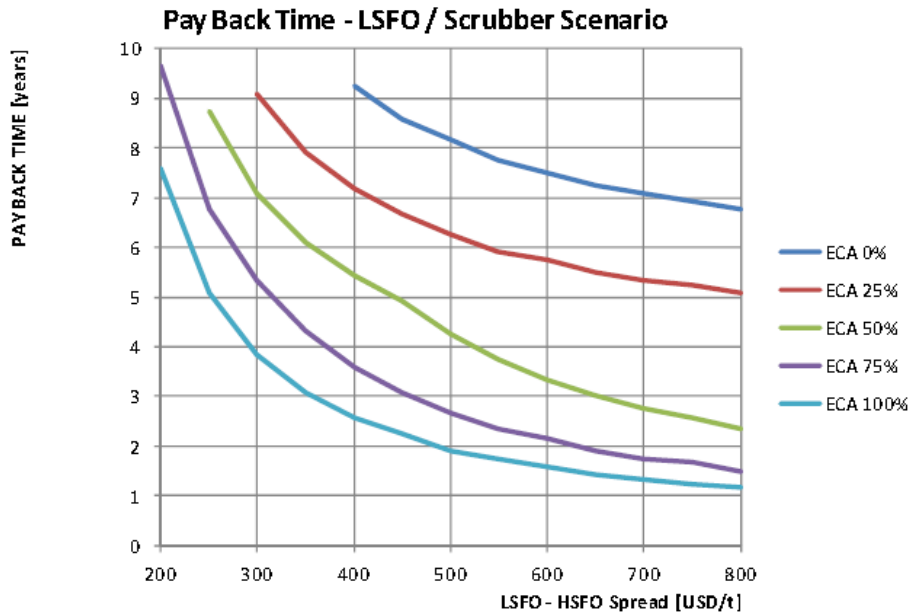

Figure 26. Break Even Analysis for Scrubber Installation on 38,500 dwt tankers (Ref. 87)

For example DS Norden operates 4 tankers similar to the case in Figure 26 with an average of 13.5 % navigation time in ECA areas. The payback time for a scrubber would thus be at least 6 years, more likely 10 years.

Currently ULSD and LSRF are the most viable marine fuel alternatives for the near future and some predict distillates to be the more likely option out through 2020 instead of exhaust scrubbers (Ref. 43).

These fuels are good for SO_x reduction since they have low sulfur content and their availability is good worldwide at bunkering ports. NO_x reduction in 2016 for ships operating in ECAs will require the installation of after treatment devices or the retrofit of emission compliant engines.

Biofuels have not made inroads into the marine fuels market and given their limited availability, higher cost, and in some cases their incompatibility issues, i.e. higher concentrations of Biodiesel (FAME) will probably not see large scale use by ship operators as a neat fuel. Since they can be blended with ULSD and LSRF they may find their way into the marine fuel market as they become more widely available. In the US biodiesel (FAME) can be blended into regular diesel fuel up to 5 % in the revised ASTM D975 Specification for Diesel Fuel Oils used for on and off road diesel applications. According to the ASTM there will be no significant change to the diesel fuel properties or their requirements (Ref 88). Labeling of the finished blend is not required so that it may not be possible for the purchaser to know whether or not the fuel contains biodiesel unless an analysis is carried out (Ref. 89). Since this specification covers off road diesel fuel there could be some use by the marine operators who use distillate fuels or will be using distillate fuels to satisfy the ECA sulfur limits or California Coastal Waters and EU port sulfur limits.

Second generation biodiesel, a.k.a. renewable diesel or HDRD may be viable for marine use if production can be scaled up and it is cost competitive. HDRD can be produced to meet current diesel fuel specifications so its use is transparent to the end user. It can be blended with petroleum diesel so like Biodiesel (FAME) it may find its way into marine use either as a neat fuel or as a blend with petroleum diesel. Currently US capacity for HDRD is 297 Million Gallons and in Europe Neste Oil has capacity of 800,000 Metric Tons (Approximately 244 Million Gallons) and new capacity is being added.

The second generation biodiesels such as HDRD made from certain feedstocks such as waste vegetable oils or animal fats are cost competitive with the distillate fuels but not residual fuel.



10. Conclusions

The following conclusions have been reached as a result of the research conducted developing this report. The future of marine fuels appears to be a combination of fuel types combined with new propulsion technologies and retrofit fuel systems and/or emissions systems.

- Given the environmental challenges facing the marine shipping industry to lower exhaust emissions of SO_x, NO_x, PM and CO₂ there will be changes in the mix of fuels that they use as they attempt to meet International and local exhaust emission requirements. It will no longer be one size fits all.
- For the present and foreseeable future the use of fossil fuels will continue to be the dominate fuel with various schemes used to meet the 1% low sulfur fuel requirements in the ECAs. One possible arrangement is to use a low sulfur residual fuel. The other is to use a blend of distillate and residual to lower the sulfur limit and the last is to have a dual fuel system which allows switching to the low sulfur distillate when needed.
- As shown in Table 9 it is difficult to find a strategy that meets all requirements. However it is possible to combine all of the above with partial LS fuel operation, so no solution should be excluded.

Table 9. Summary of Evaluation of Propellant Systems

	IFO	LSFO	MGO/GTL/ BTL	HVO/SVO/ FAME	MeOH	DME/LPG	LNG/LBG
Engine and fuel system cost	Drop-in	Drop-in	Drop-in	Drop-in	Dual fuel	Gas tank	Dual fuel Cryo tanks
Projected fuel cost		Refining	Refining	Land use		Infra-structure	Infra-structure
Emission abatement cost	SO _x , NO _x , PM, CO ₂	NO _x , PM, CO ₂					
Safety related cost					Flash point	Ventilation	Press/temp
Indirect cost				Ethics	Cargo space	Cargo space	Cargo space

	Serious impediment
	Significant cost
	Feasible solution available

- With the arrival of the 2015 ECA sulfur limit of 0.1% some are predicting a switch to mostly distillate fuel assuming that a 0.1% LSRF will not be available and this trend is predicted to last until 2020.
- Exhaust scrubbers are a viable alternative to using lower sulfur fuels and have been shown to be effective in marine installations but as of this date not many ship scrubber installations are in existence, not enough to indicate a major trend toward their use versus using lower sulfur fuels.
- Natural Gas stored as LNG is definitely a viable alternative propulsion fuel for ships and has been demonstrated many times in vessels on fixed and coastal trade routes and is continuing to appear in new builds that will be using LNG fuel systems and gas engines. Development of a global LNG bunkering system is critical to the expansion of this fuel into the larger ship sizes that travel on international routes.
- LNG should remain cost competitive with marine fossil fuels for the foreseeable future and provides a strong incentive for new builds to have gas engines and LNG fuel systems. The higher initial cost of constructing a gas fueled ship can be recovered over the lifetime from the

lower fuel costs. In addition LNG fueled ships that spend a large part of their time operating in ECAs will be able to comply with the low sulfur and NOx tier 3 requirements with gas engines without having to switch fuels or add exhaust after treatment emission devices for SOx and NOx reduction.

- For NOx compliance in 2016 for new ships that operate in the ECAs the consensus seemed to be that they would be equipped with after treatment devices to reduce NOx emissions. Ships using gas fired engines may be able to comply without the need for after treatment device. There are gas engines available that are certified as complying with the IMO Tier 3 NOx limits.
- Compliance with the new emission requirements will raise operating costs for ship owners and operators in terms of new construction ships that will have more complicated fuel systems, and perhaps after treatment devices and more expensive low sulfur fuels when in the ECAs and other low sulfur compliance ports and coastal waters. Some existing ships may also have to be retrofitted with dual fossil fuel systems for fuel switching when they enter the ECAs.
- Biofuels do not seem to be an alternative at present given their limited availability and high cost. In particular FAME Biodiesel because of its quality issues does not look like a good candidate for marine use in large ships.
- It is early to determine what course ship owners are going to take for compliance with the Tier 3 ECA NOx requirements in 2016. As contracts are awarded for ships that will be new as of that date the trend will be more discernible.
- The use of LNG as a marine fuel is projected to grow to 15 MTons a year by 2020 to a possible 66 million tonnes in 2025.

11. Recommendations

Continue this study to determine trends and get firsthand information on how ship operators are complying with the ECA requirements and monitor the progress of large LNG fueled ships coming into the shipping mix and progress on establishing marine LNG bunkering facilities.

Monitor the actions ship owners and operators are taking for current compliance now and for the stricter emission requirements coming into effect in 2016 and 2020.

Continue to study the progress of biofuel producers and their ability to produce low cost high volume fuels for the marine shipping industry.

References:

1. EPA Program Update - Office of Transportation and Air Quality, EPA-420-F-11-024, July 2011
2. ECAs, Regional Workshop on the Ratification and Implementation of MARPOL Annex VI, Athens Greece, 26-27 Oct. 2010, Robert Meech
3. Sustainable use of the seas, Swedish Agency for Marine and Water Management, Thomas Johansson, Ref. 31 DTI
4. Verification of compliance of the flag states, Clea Henriksen, Danish Maritime Authority (presentation 2011.11.22), Ref. 17 DTI
5. Potential of Biofuel for Shipping or Final report, Ecofys by order of European Maritime Safety Agency (EMSA) 2012, Ref. 1 DTI
6. Review of Maritime Transport 2012, UN Publication, Document Number - UNCTAD/RMT/2012 UNITED NATIONS PUBLICATION
7. Starcrest, 2005
8. Operation on Low-Sulfur Fuels, MAN B&W, Document # 5510-0075-00ppr, February 2010
9. International: IMO Marine Engine Regulations, Dieselnets.com
10. Bunker Fuel: Supply, Demand and Pricing, Bunkerworld Business Exchange, Purvin&Gertz, Houston March 2010, http://i.pmcndn.net/p/events/2010/houston/presentations/1_2_Barrow.pdf, Ref. 25 DTI
11. Second IMO GHG Study 2009, Øyvind Buhaug, James J. Corbet, Veronika Eyring, IMO, Ref. 2 DTI
12. Technology Outlook 2020, Elisabeth Harstad, DNV, Ref. 4 DTI
13. Will Low-Sulfur Fuel be Sufficiently Available Asks ICS, 23 July 2012, MarineLink.com
14. Maersk PPT Presentation or Role of Biofuels in Shipping Industry by Jacob Sterling
15. LNG for the maritime sector closer to reality thanks to EU Supported Project, 29 January 2013, TEN-T Executive Agency Press Release
16. EU Funds Study of Barriers to LNG Fueling, 29 January 2013, Marine Log
17. Effship Work Package 2: Future Marine Fuels, ScandiNAOS AB, Sweden <http://www.effship.com/WP2.htm>, Ref. 5 DTI

18. "LPG operation makes promising advances as future green fuel", René Sejer Laursen, MAN B&W, Ref. 27 DTI
19. Johan Algell, Swedish Marine Technology Forum, Ref. 33 DTI
20. "Second IMO GHG Study 2009", Øyvind Buhaug, James J. Corbet, Veronika Eyring, IMO, Ref. 2 DTI
21. "Turning necessity into advantage – sustainability as a strategy", Karl Jivén, Sustainability Manager Maersk Line Scandinavia, Uddevalla 30th of November 2011, Ref. 8 DTI
22. "Low Cost Fuel Oil Alternative: Development on Track", 26 January 2013, George Backwell, Maritime Propulsion)
23. W-http://en.wikipedia.org/wiki/Pyrolysis_oil
24. FAME is Not (Necessarily) the Answer, Biofuels Digest, 31 January 2013, Pamela Serino, Defense Logistics Agency Energy)
25. "LNG Fuelled ships The Norwegian Experience and Future Development Trends", Dag Stenersen, MARINTEK, MARKIS Seminar, Uddevalla, 2011-11-30, Ref. 30 DTI
26. "North European LNG Infrastructure Project", Danish Maritime Authority
<http://www.dma.dk/themes/LNGInfrastructureproject/Sider/Papersandpresentations.aspx>,
Ref. 26 DTI
27. European W2W analysis from JEC, Ref. 28 DTI
28. Bio-LNG :a clean and cool biofuel for ships (presentation) Lloyd's maritime academy London: 12th of November 2008, Ref. 32 DTI
29. Lloyd's Register , "Understanding Exhaust Gas Treatment Systems, Guidance for Shipowners and Operators, June 2012, www.lr.org/eca
30. Maritime Reporter Press Release, 18 July 2012
31. "Marine Diesel Engine –Mighty Midget" Exhaust Gas Scrubber", by George Blackwell, 19 January 2013, Maritime Propulsion
32. "Messina Newbuilds to have Wartsila Exhaust Gas Cleaning, 26 February 2013, Marine Log
33. "Wärtsilä Diesel Engines Mated with Scrubbers for New Lakers", 7 February 2012, George Backwell, Maritime Propulsion

34. "Reduction of sulfur - which solution is more economical?" - a cost-benefit study of different abatement technologies, Christian Klint Nielsen, Green Ship of the Future (presentation 2011.11.22), Ref. 19 DTI
35. Leif Holmberg, Transatlantic AB, Ref. 34 DTI
36. Glander International, Inc. Presentation, April 2012
37. www.bunkerworld.com
38. Bunkerworld Magazine, March 2011
39. Biodiesel Handling and Use Guide, Fourth Edition, Revised December 2009, NREL/TP-540-43672
40. Alternative Fuels Development and Testing, NAVSEA05, Ed Godfrey
Surface Navy Symposium, 12 January 2011
41. Beta Analytic Web Site @ <http://www.betalabservices.com/biofuels/renewable-diesel-hdrd.html>
42. US News Weekly, July 19, 2012, Michael. C. Lynch
43. Fuel for Thought, Greg Trauthwein, Maritime Reporter and Engineering News, June 2012
44. LNG Gains Traction as Alternative Fuel, Robert Kunkel, 9 June 2011, MarineLink.com
45. "Japanese Marine Engine Major Plans LNG Engine", WSJ, Marine link, 26 November 2012
46. Natural Gas for Marine Vessels, U.S. Market Opportunities, April 2012, American Clean Skies Foundation
47. Lloyd's List, Norway's NOx Fund Eases the Cost of Conversion, 07 September 2010
48. Germanischer Lloyd (GL) Article "Will it be Cost-Effective?" @ www.gl-group.com
49. Germanischer Lloyd (GL) Article - LNG Supply Chain @ www.gl-group.com
50. Bunkerworld News, "Shell Targets LNG Bunker Market" 11 July 2012
51. Marinelink.com, LNG Bunker Port in Netherlands a Step Closer, 13 July 2012
52. "Rotterdam, Gothenburg Join to Speed Up LNG Bunker Supply", 12 October 2012, Press Release, MarineLink.com
53. "EU funding for LNG bunkering vessel project", January 11, 2013, Marine Log
54. www.Marinelog.com, JV Plans European LNG Marine Fuel Infrastructure, 6 August 2012

55. "Engine of Change", Marine Log, pg. 19, June 2012
56. Marinelink.com, LNG Bunkering in Singapore Sets up Joint Industry Project, 13 April 2012
57. "LNG-fuelled deep sea shipping-The outlook for LNG bunker and LNG-fuelled newbuild demand up to 2025", August 2012, Lloyd's Register, www.lr.org/bunkering
58. "Natural gas for ship propulsion in Denmark, Possibilities for using LNG and CNG on ferry and cargo routes", Environmental Project No. 1338 2010, Frank Stuer-Lauridsen, Jesper B. Nielsen, Thomas Odgaard, Mikkel Birkeland, Claus Winter Graugaard, Lars Petter Blikom, Núria Muro-Suné, Morten Andersen and Frederik Øvlisen. Litehauz, IncentivePartners, DNV, Rambøll Oil & Gas, Ref. 22 DTI
59. "Shell moves to boost U.S. Availability of LNG Fuel", Marine Log, 5 March 2013
60. DNV Report, Experience with Low Sulfur Fuel in European Ports, 25 June 2010, John Stirling
61. MarineLink.com, Will Low-Sulfur Fuel be Sufficiently Available Asks ICS, 23 July 2012
62. Presentation, "Lessons learned from the Norwegian experience of Using LNG as fuel for Ships" by Henrik O. Madsen, CEO, DNV, 23 March 2011 at Green Ship Technology Conference, Oslo 2011
63. "Wartsila to Introduce LNG Technology in Passenger Vessels", 20 May 2011, Wartsila article
64. "LNG-Fueled Cruise Ferry Delivered by STX Turku Shipyard", 10 January 2013, Marine Log
65. "Fjord Line world's first cruise ferry powered by natural gas alone", Maritime Propulsion, Peter Pospiech, January 01, 2013).
66. "Fiskerstrand to Build Two LNG Fueled Fish Feed Vessels", 27 February 2013, Marine Log
67. "Model for the Market?", June 2012 Yearbook, pg. 42, Marine Log
68. Marine Log, 5 Feb 2012
69. www.Marinelog.com, Quebec Orders Dual Fuel Ferry at Fincantieri, 30 July 2012
70. "Wartsila gets equipment order for LNG Fueled Quebec Ferry", Marine Log, 3 December 2012
71. "Incat Launches LNG Fueled High Speed RO/RO", Marine Log, 21 November 2012
72. "Wärtsilä to Supply Main Engines for China's First gas fueled Tugs", 11 July 2012 Marine Log
73. "Who Has Gas And Who Wants It?", March 2013, John R. Snyder, Marine Log
74. www.ship-technology.com

75. "WSF Reveals More Details of Proposed Conversions to LNG Fueling", Marine Log, 28 June 2012
76. "Staten Island Ferry Conversion Planned", MarineLink.com, 01 January 2013
77. "NASSCO Books Order for TOTE Orca Class LNG Conversions", Marine Log, 28 January 2013)
78. www.marinelog.com, TOTE Receives ECA Waiver to Pursue LNG Conversion, 5 August 2012
79. "NASSCO to Design TOTE LNG Propulsion Conversion", Press Release, MarineLink.com, 28 Jan 2012)
80. http://en.wikipedia.org/wiki/LNG_carrier#cite_note-1
81. MarineLink.com, "BV Approves LNG-Powered Ultra Large Containership", 19 January 2012.
82. Maritime Reporter and Engineering news, "Bulk Carriers Debuts in Athens "Green Dolphin", July 2012 Edition
83. "TOTE Goes Gas", MarineLink, Greg Trauthwein, Editor, 23 January 2013)
84. "Dynamic Fuels and Solazyme Partner to Supply Renewable Fuel to U.S. Navy", Washington, Dec. 5, 2011 (GLOBE NEWSWIRE)
85. "Stena Looks to Methanol", 3 December 2012, Green Port
86. "Ferry Tales February: Problems, Problems!", 18 February 2013, Justin Merrigan, Baird Maritime
87. "Life Cycle Assessment of Present and Future Marine Fuels", Selma Bengtsson, Chalmers University Sweden 2011. Ref. 7 DTI
88. ASTM Standardization News, New Biodiesel Specifications Published by ASTM International, November/December 2008, ASTM Staff: David Bradley
89. DieselNet.com, Fuel Regulations US
90. "NO_x pollution and Emission Control Areas (ECA) – The engine manufacturers answer to the challenges", Johan Kaltoft, Michael Finch Pedersen, MAN Diesel (presentation 2011.11.22), Ref. 15 DTI
91. "Sulfur reduction with sea and fresh water scrubbers - Challenges and experiences from DFDS ship Tor Ficara", Jens Peter Hansen, Alfa Laval Aalborg (presentation 2011.11.22), Ref. 18 DTI

Appendix A – Marine After Exhaust Treatment Systems

SCR and EGR Systems

MAN Diesel & Turbo is currently preparing to launch both SCR and advanced EGR solutions on the market (Ref. 90). The EGR solution will incorporate a high pressure loop with integrated scrubber, so that both NO_x and SO_x can be reduced. The SCR solution only reduces NO_x. See Figures 27 and 28.

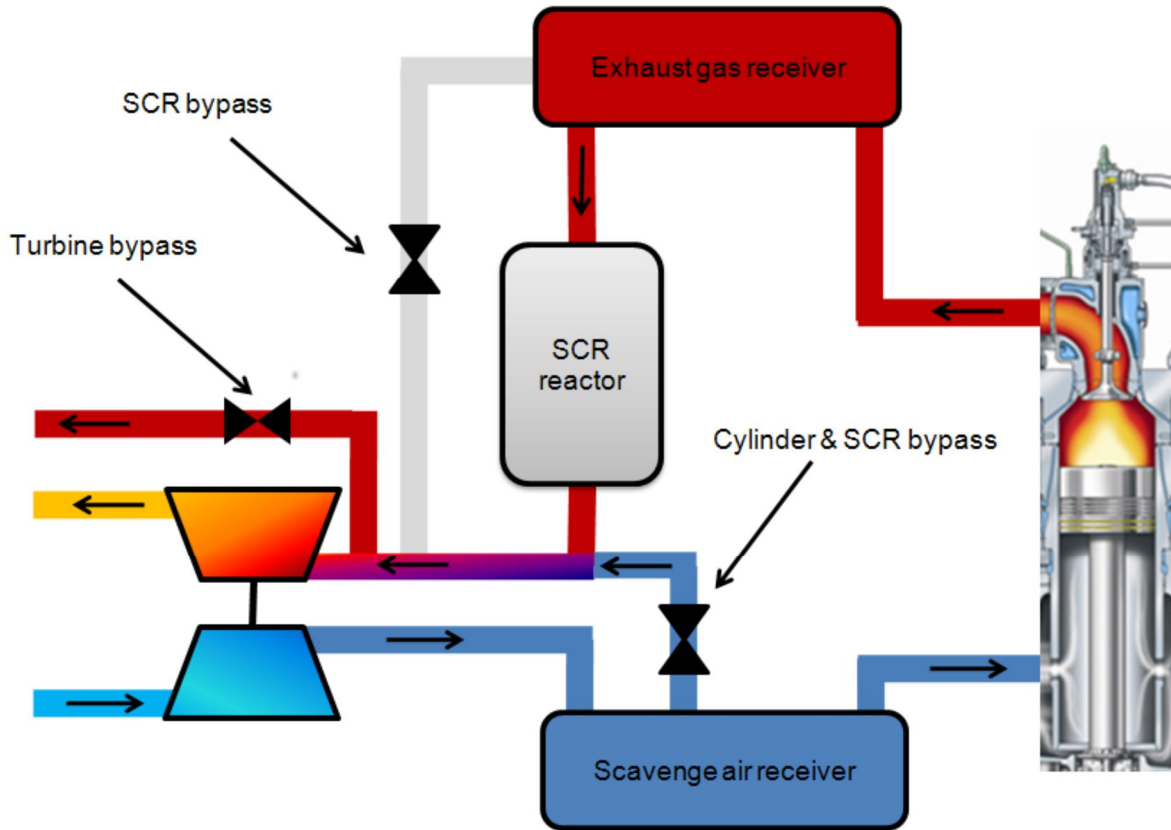

Figure 27. SCR Solution by MAN (reduces NO_x)

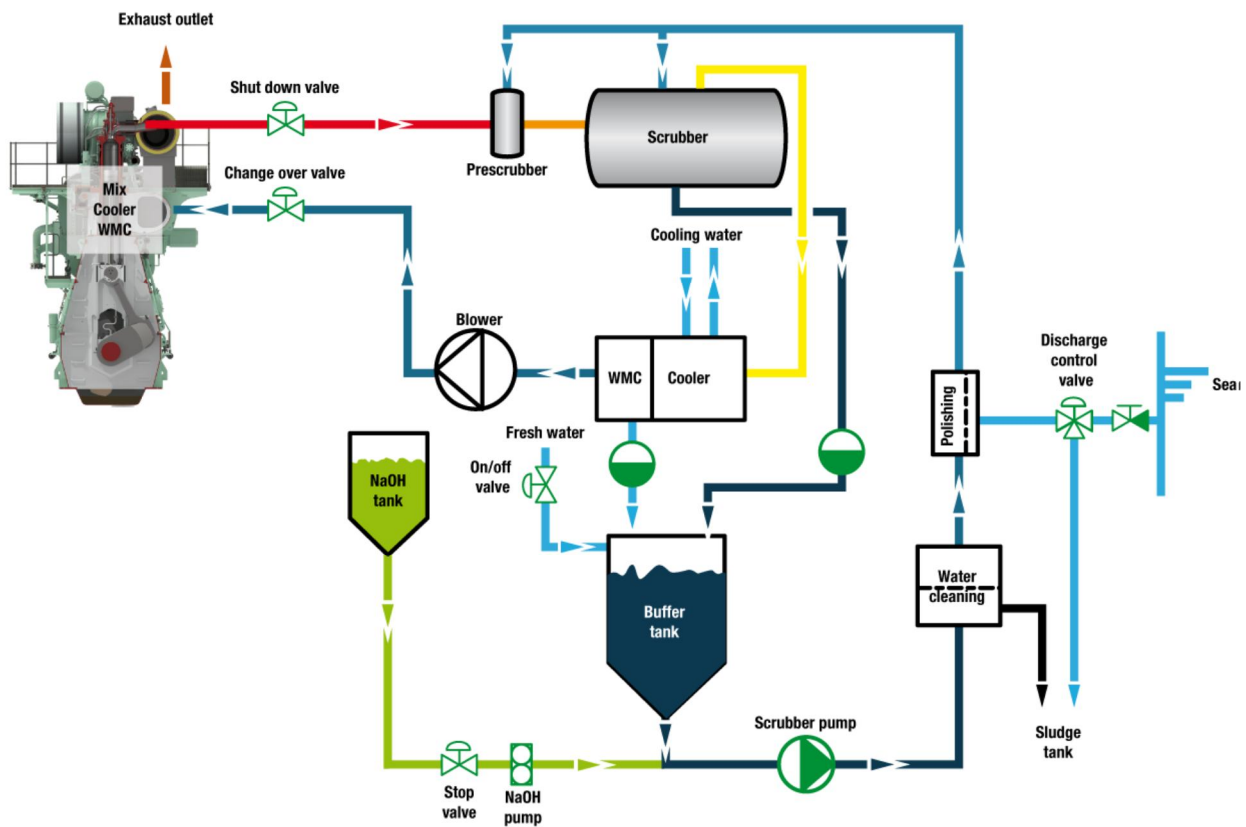

Figure 28. Advanced EGR System by MAN

(Reduces both NO_x and SO_x - SO_x however only by 20%)

Scrubber Systems

Alfa Laval has recently launched retrofit scrubbers on the market. Internal tests have shown that the systems are effective (Ref. 91). See Figure 29.

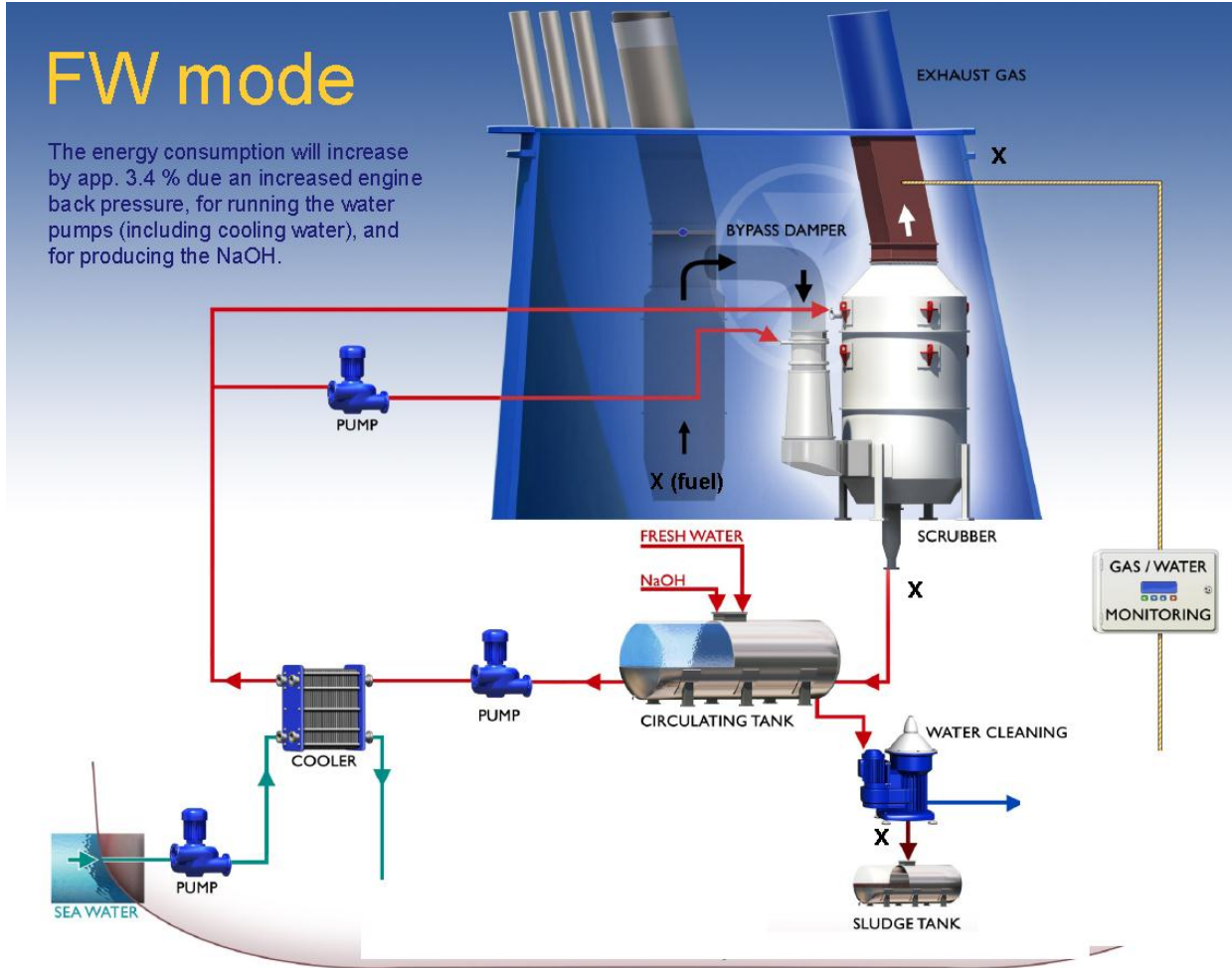

Figure 29. Scrubber System by Alfa Laval

Alfa Laval equipped DFDS Ficaria Seaways with presumably the world's largest retrofit scrubber in 2009. See Figure 30.



Figure 30. Ficaria Seaways Equipped with Presumably World’s Largest Retrofit Scrubber in 2009
(Picture: Alfa Laval)

Wärtsilä offers a closed system fresh water scrubber as shown in Figure 31.

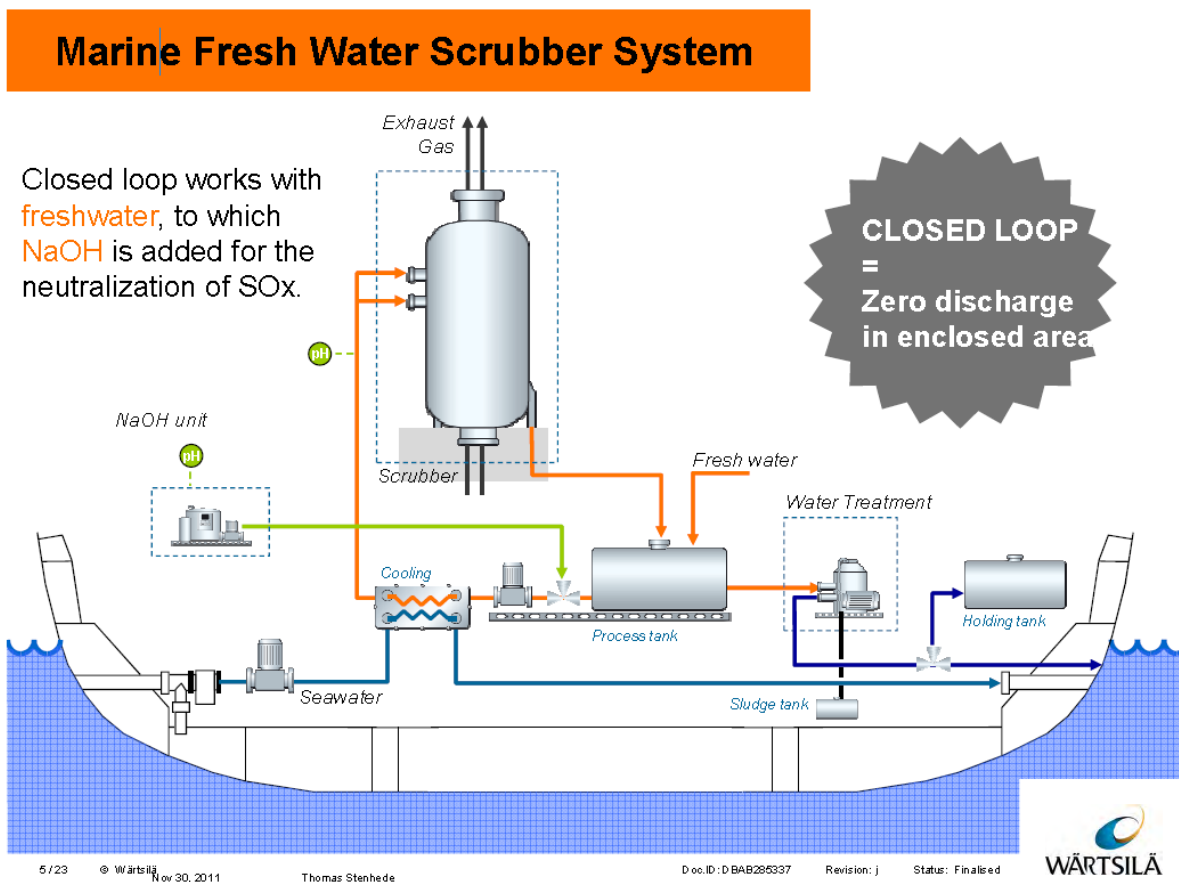

Figure 31. Closed Loop Scrubber by Wärtsilä

Couple Systems GmbH supplies a Dry EGCS system (Figure 32), such as mounted on the MV Timbus. The system is based on limestone $\text{Ca}(\text{OH})_2$ which turns into gypsum during the sulfur neutralization process. The pressure loss is very low at 600-800 Pascal compared to wet scrubbers. The pressure drop of wet scrubbers is about 3000 Pascal. The cost for the system is approximately 770,000 EUR for 3.5 MW system and 1,350,000 EUR for 12 MW system (see Figure 15).

However, infrastructure is needed for the new and used sorption product.

DryEGCS – The Dry Option

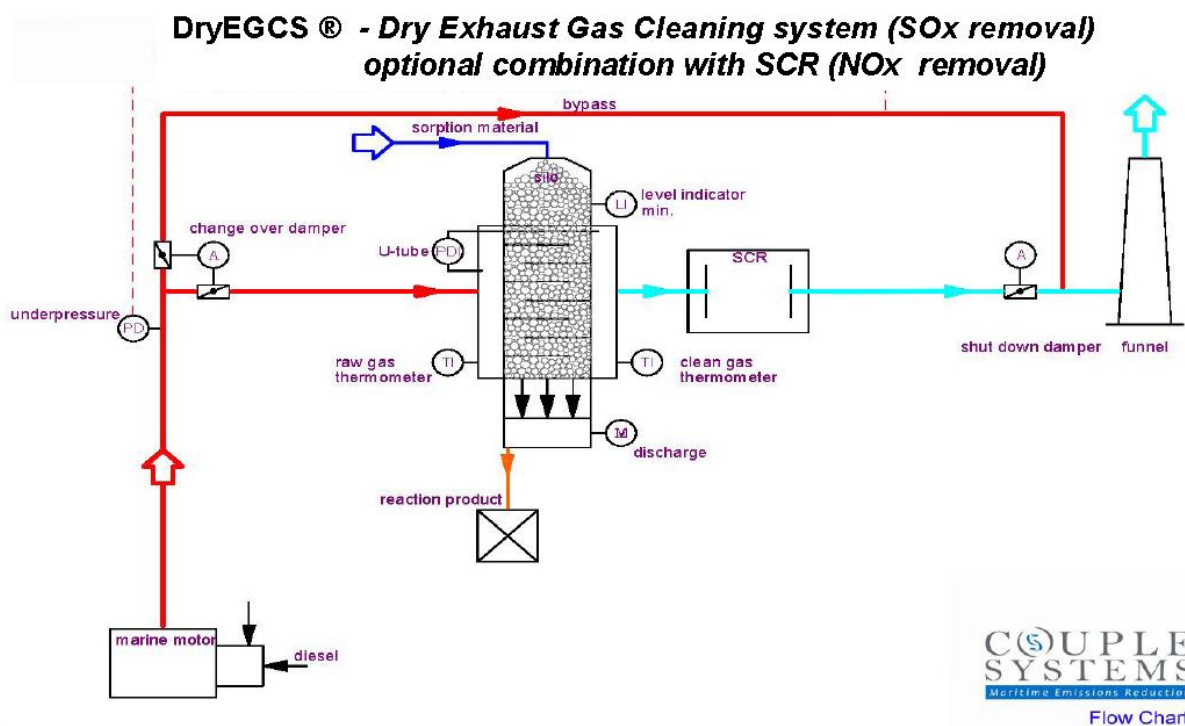

Figure 32. Dry Scrubber System by Couple Systems, Germany